



Horn Loudspeakers

METAL HORNS

P-HS-15(T)

Bracket and all outside nuts and bolts in stainless steel.

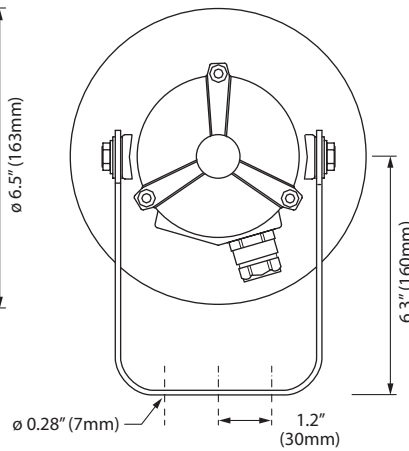
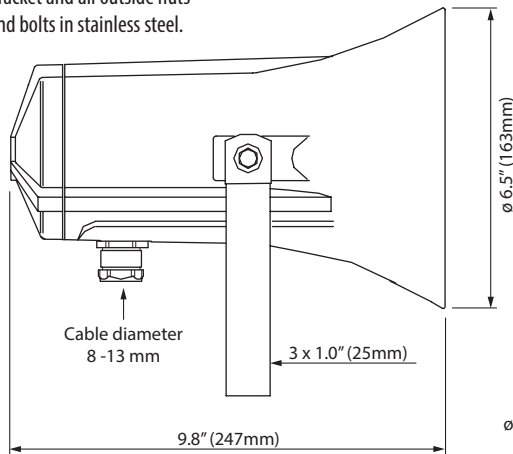

Circuit Diagram

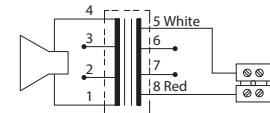

100 V = 5 (white) ; 8 (red)
 70 V = Remove red wire from 8 to 7

Secondary nominal tapings:

1:4 15.0 W 1:2 4.5 W
 1:3 8.0 W 3:4 3.5 W
 2:4 5.0 W 2:3 1.0 W

8 ohm version available

Specifications

Material / Color	Aluminum alloy / RAL 7035
Mounting	Bracket
Termination	Inside screw terminals
Weight	6.0 lbs (2.7 kg)
IP-rating (UL Equivalent)	67
Max. / min. ambient temperature	302 °F / -58 °F (150 °C / -50 °C)
Rated / max. power	15 W / 20 W
SPL 1W/1m	107 dB
SPL rated power	118 dB
Effective freq. range	350 – 7500 Hz
Dispersion (-6dB) 1kHz / 4kHz	150° / 40°
Options	Impedances, colors, labels

Sound pressure levels at 1W/1m

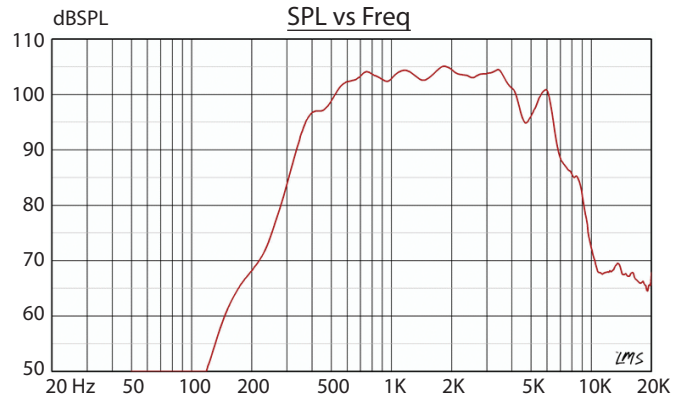

Many DNH products are available in different colors, impedances and power ratings.

Industrial Speakers



ISO 9001 Certified

Guardian Telecom is proud to be a supplier of the full line of DNH loudspeakers. Since 1946 DNH has been a leading manufacturer of one of the world's largest high quality range of loudspeakers for industrial and commercial applications. For off the shelf stock items to tailored products, contact a Guardian sales representative to discuss your specific project needs and the equipment that will meet your demands.



tough. trusted. true.



Installation, Operation and Maintenance Procedures

- Fasten the bracket to wall with 1-3 screws and ensure to use all washers in the same position that the loudspeaker is delivered with. (To isolate the main body from the bracket)
- Open the lid back 3 screws. Lead cable through cable gland and connect to terminal.
- To change the position of the loudspeaker, please adjust the bracket (by loosening / tightening the screws) as required.
- For optimum performance, always use the correct voltage / power and operate within the frequency limits as stated.
- The aluminum surface of the loudspeaker should be regularly treated with paint at the same interval as with other similar outdoor equipment.
- **Do not** open loudspeaker when energized.
- This loudspeaker is supplied with a 2 year warranty against defective workmanship.



The Manufacturer reserves the right to alter specifications without notice.