

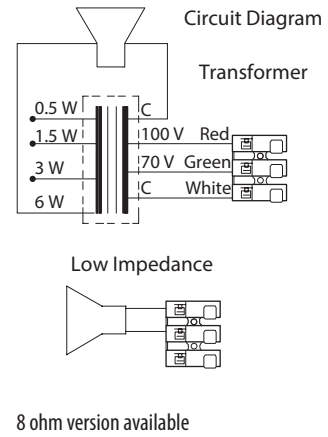

Cabinet Loudspeakers

P-CW-4(T)

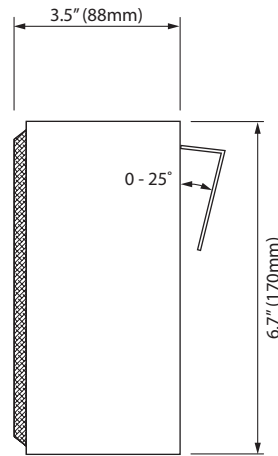
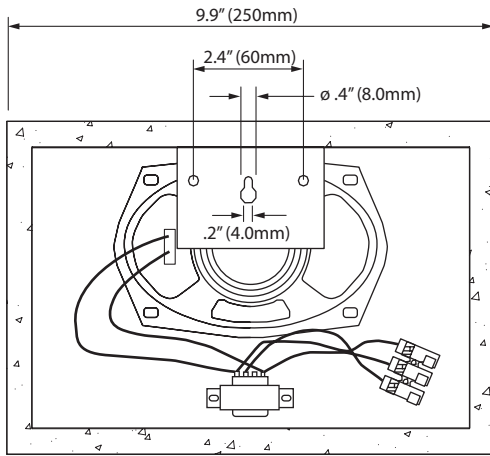

70/100 volt combined transformer:

Primary connections:

White : Green 70 V
White : Red 100 V

Secondary nominal tapings:

C: 6 6.0 W C: 1.5 1.5 W
C: 3 3.0 W C: 0.5 0.5 W

Specifications

Material / Color	Particle board / walnut
Mounting	Screws, keyhole
Termination	Spring clamps
Weight	2.8 lbs (1.25 kg)
Max. / min. ambient temperature	194°F / -4 °F (90°C / -20°C)
Rated / max. power	6W / 8 W
SPL 1W/1m	90 dB
SPL rated power	97 dB
Effective freq. range	150 – 20000 Hz
Dispersion (-6dB) 1kHz / 4kHz	140° / 80°
Options	Impedances, colors, labels

Sound pressure levels at 1W/1m w/P-4x6

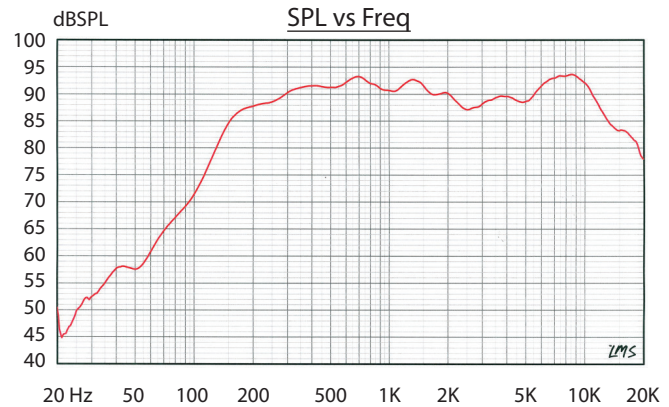

Industrial Speakers



ISO 9001 Certified

Guardian Telecom is proud to be a supplier of the full line of DNH loudspeakers. Since 1946 DNH has been a leading manufacturer of one of the world's largest high quality range of loudspeakers for industrial and commercial applications. For off the shelf stock items to tailored products, contact a Guardian sales representative to discuss your specific project needs and the equipment that will meet your demands.



tough. trusted. true.



Installation, Operation and Maintenance Procedures

- Connect to terminal (70 V or 100 V) and select required tapping in to the transformer.
- Screw the bracket on the wall, and fasten the cabinet to the bracket with one screw.
- For optimum performance, always use the correct voltage / power and operate within the frequency limits as stated.
- **Do not** open the loudspeaker when energized.
- This loudspeaker is supplied with a 2 year warranty against defective workmanship.



The Manufacturer reserves the right to alter specifications without notice.



GUARDIAN TELECOM LTD.
Calgary, Alberta, Canada
Telephone: 403 258 3100 Facsimile: 403 255 2595
1 800 363 8010 (North America)
info@guardiantelecom.com | www.guardiantelecom.com

