

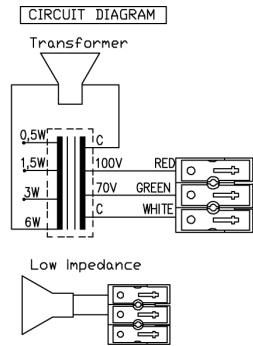

Ceiling Loudspeakers | Metal

P-B-620(T)

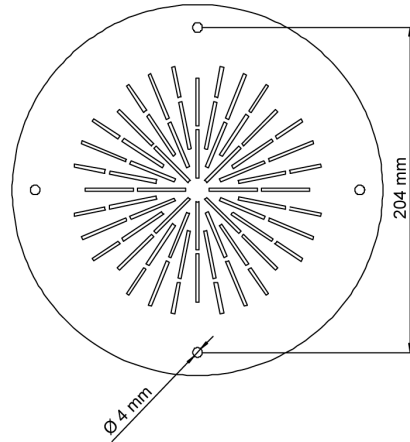
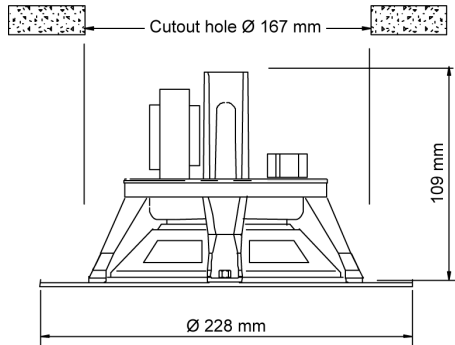

70/100 Volt Combined Transformer:

Primary connections:

White : Green 70V

White : Red 100V

Secondary nominal tapings:

C : 6W 6.0W

C : 3W 3.0W

C : 1.5W 1.5W

C : 0.5W 0.5W

Specifications

Material / Color	Aluminum / RAL9010
Mounting	4 screws
Termination	Spring clamp
Weight	1.92 lbs (0.87 kg)
Max. / min. ambient temperature	194 °F / -4 °F (90 °C / -20 °C)
Rated / max. power	6W / 15W
SPL 1W/1m	92 dB
SPL rated power	99 dB
Effective freq. range	90 – 20000 Hz
Dispersion (-6dB) 1kHz / 4kHz	130° / 60°
Options	Impedance, color, label

Sound pressure levels at different frequencies at 1W/1m

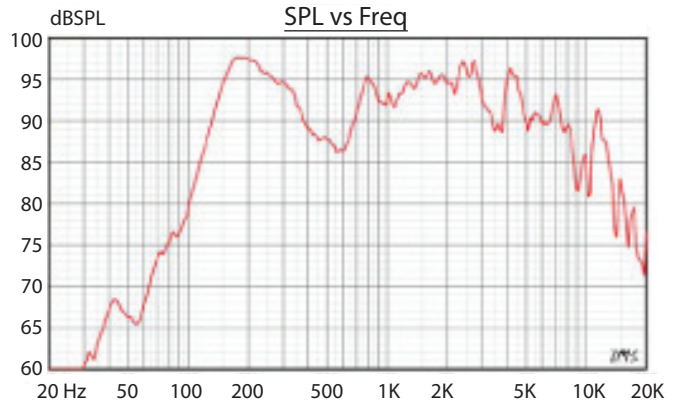

Industrial Speakers



ISO 9001 Certified

Guardian Telecom is proud to be a supplier of the full line of DNH loudspeakers. Since 1946 DNH has been a leading manufacturer of one of the world's largest high quality range of loudspeakers for industrial and commercial applications. For off the shelf stock items to tailored products, contact a Guardian sales representative to discuss your specific project needs and the equipment that will meet your demands.



tough. trusted. true.



Installation, Operation and Maintenance Procedures

- Connect cable to terminal (70V or 100V) and select required tapping.
- Install loudspeaker grill by screws.
- For optimum performance, always use the correct voltage / power and operate within the frequency limits as stated.
- Do not open loudspeaker is energized.
- This loudspeaker is supplied with a 2 year warranty against defective workmanship by the manufacturer.

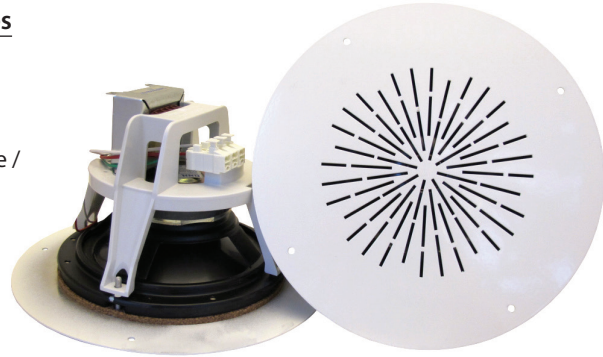

The Manufacturer reserves the right to alter specifications without notice.