

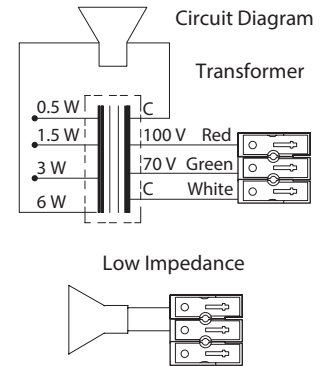

Cabinet Loudspeakers

P-B-406(T)

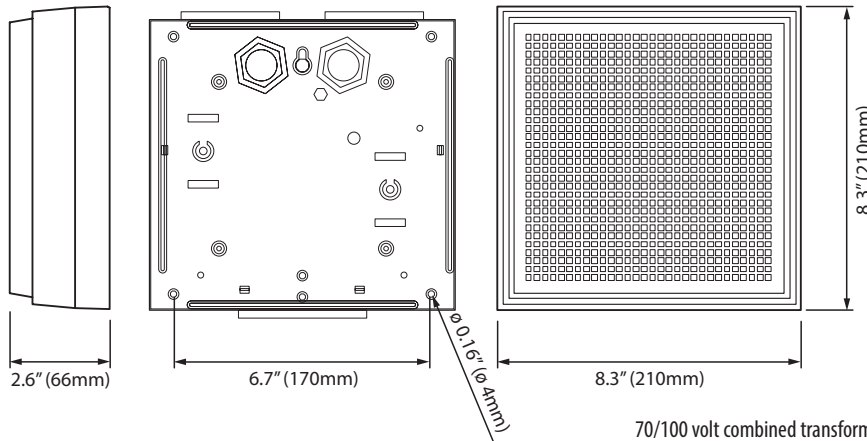

70/100 volt combined transformer:

Primary connections:

White : Green 70V
White : Red 100V

Secondary nominal tapings:

C:6 6.0 W C:1.5 1.5 W
C:3 3.0 W C:0.5 0.5 W

8 ohm version available

Specifications

Material / Color	ABS/ Light grey
Mounting	Screws and keyhole
Termination	Spring clamp
Weight	2.42 lbs (1.1 kg)
IP-rating (UL Equivalent)	0
Max. / min. amb. temp	194 °F / -4 °F (90°C / -20°C)
Rated / max. power	6W / 8W
SPL 1W/1m	92 db
SPL rated power	98 db
Effective freq. range	180 - 14000 Hz
Dispersion (-6dB) 1kHz / 4kHz	170° / 50°
Options	Impedance, color, label

Sound pressure levels at 1W/1m w/P6-15B

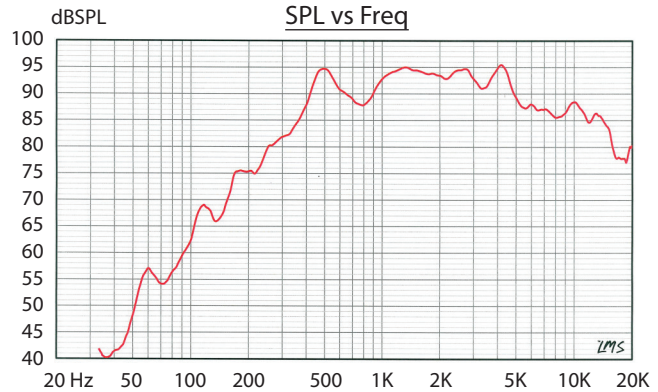

Many DNH products are available in different colors, impedances and power ratings.

Industrial Speakers



ISO 9001 Certified

Guardian Telecom is proud to be a supplier of the full line of DNH loudspeakers. Since 1946 DNH has been a leading manufacturer of one of the world's largest high quality range of loudspeakers for industrial and commercial applications. For off the shelf stock items to tailored products, contact a Guardian sales representative to discuss your specific project needs and the equipment that will meet your demands.



tough. trusted. true.



SAI GLOBAL
ISO 9001:2015

Installation, Operation and Maintenance Procedures

- Remove backplate by bending back two sides of cabinet.
- Screw the backplate to wall or ceiling.
- Lead cable through a cable entry, connect to terminal (70 V or 100 V and select required tapping in to the transformer.
- Clip on the cabinet to the backplate.
- For optimum performance, always use the correct voltage / power and operate within the frequency limits as stated.
- **Do not** open loudspeaker when energized.
- This loudspeaker is supplied with a 2 year warranty against defective workmanship.

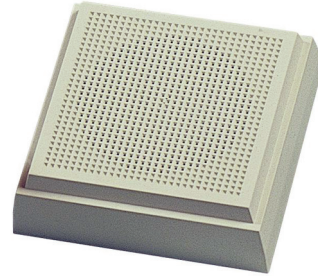

The Manufacturer reserves the right to alter specifications without notice.



GUARDIAN TELECOM LTD.
Calgary, Alberta, Canada
Telephone: 403 258 3100 Facsimile: 403 255 2595
1 800 363 8010 (North America)
info@guardiantelecom.com | www.guardiantelecom.com

