

WTT-V-H WTR-V-H SERIES

Hazardous Area

Watertight VoIP Telephones



WTT-V-H WTR-V-H SERIES WATERTIGHT INDUSTRIAL VoIP HAZARDOUS TELEPHONES

- WTT-V-H-30 Watertight Telephone/Metal Keypad/Curly Cord
- WTT-V-H-40 Watertight Telephone/Metal Keypad/Armored Handset Cord
- WTR-V-H-11 Watertight Ringdown Telephone/Curly Cord
- WTR-V-H-41 Watertight Ringdown Telephone/Armored Handset Cord

FEATURES and BENEFITS

- "Full" duplex operation
- PoE 802.3af enabled (Power-over-Ethernet) or alternate power source
- Compatible with most SIP-based IP-PBX servers that comply with SIP (RFC 3261). (Refer to the Guardian VoIP web page for a list of certified servers)
- Network web management interface
- Guardian Discovery Utility makes it easy to detect, locate and launch the web based configuration screens
- Product self diagnostic testing available through web interface
- Network adjustable speaker volume and microphone sensitivity
- Network downloadable firmware
- Remote programming – allows you to manage your network from a central location
- Corrosion protected and powder coated steel, full gasket faceplate
- WTT-V-H models have metal keypads for extended life
- Vandal resistant armored handset cord with lanyard on WTT-40-V-H & WTR-41-V-H
- Heavy duty G Type industrial handset
- Integrated mounting feet
- Handset retainers to maintain on-hook status
- Spring loaded door
- Drill guides provided for top & bottom mount glands
- Electret noise reducing microphone for clear communication
- Water/dust-tight thermoplastic resin enclosure, Type 4X & IP66
- Waterproof connections & stainless steel fittings for longer life
- Magnetic reed hook switch to reduce parts subject to wear
- Modular parts for easy service
- Hearing aid compatible & receiver volume adjustment

WTT-V-H WTR-V-H SERIES

Guardian's WTT-V-H/WTR-V-H SERIES Water Tight Industrial Telephone Series offer maximum efficiency under extreme environmental conditions. The sturdy thermoplastic resin enclosure protects the internal circuitry against wind blown dust, rain, corrosion, splashing and high pressure water.

In addition to being certified for use in Class I, Division 2 applications, it has both Type 4X & IP66 ratings which make it ideal for use in offshore or corrosive atmospheres.

APPLICATIONS

Guardian's WTT-V-H & WTR-V-H telephones with Type 4X & IP66 ratings, these are ideal telephones for extreme hazardous conditions such as:

- | | | |
|-----------------|----------------------|------------------------------|
| Refineries | Marine Installations | Bulk Fuel Loading Facilities |
| Drilling Rigs | Offshore Platforms | Desert & Arctic Conditions |
| Chemical Plants | Aerospace Sites | and more . . . |

ACCESSORIES

- External ringer
- Visual Alserter



tough. trusted. true.



OVERALL DIMENSIONS

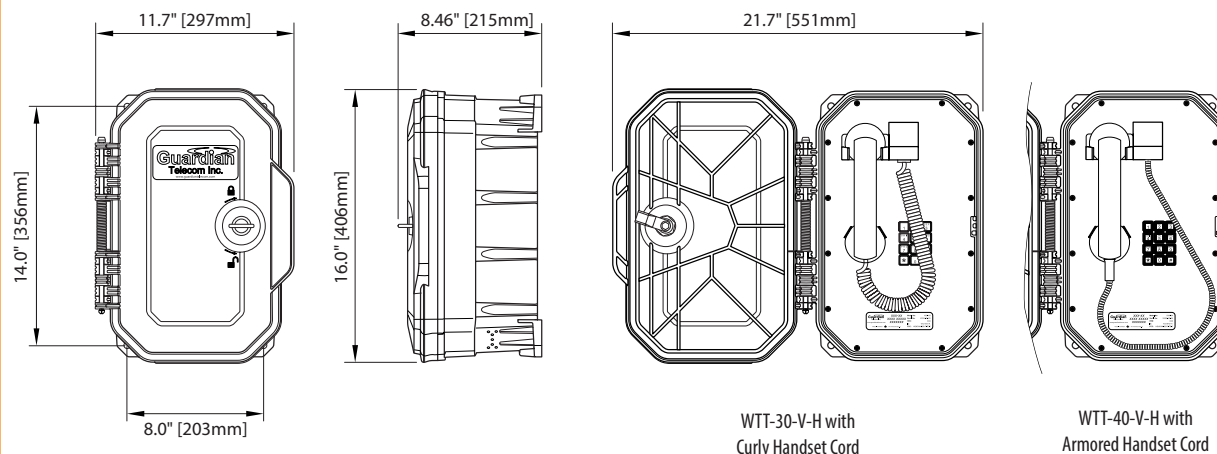

WTT-V-H Watertight VoIP Telephones • WTR-V-H Watertight VoIP Ringdown Telephones

ENGINEERING SPECIFICATIONS

ELECTRICAL PERFORMANCE

Network Rate Protocol 10/100 Mbps
SIP (RFC 3261 Compliant)

ELECTRICAL REQUIREMENTS

Power Requirements 802.3 af Compliant
12-24V @ 1A
Auxiliary Relay 0.5A @ 30VDC
Codecs Supported: G.711 (Mu-law)
G.711 (A-law)
G.729.1 (G729) and (G729EV)
G.722.1 (SIREN7)
G.722.2 (AMR-WB)

MECHANICAL SPECIFICATIONS

Hook Switch (Cradle Switch) Life >1 000 000 Operations
Body Construction Thermoplastic Resin
Faceplate Corrosion Protected & Powder Coated
Net Weight 11.8 lbs (5.4 kg)
Shipping Weight 14.0 lbs (6.3 kg)
Shipping Dimensions (L x W x D) 20.0" x 15.0" x 12.0" (508 x 381 x 305 mm)
Hand Set Construction High Impact Polycarbonate
Mounting Vertical Wall
Microphone Noise Reducing Electret
Receiver Hearing Aid Compatible
Hardware Material Stainless Steel
Connection Fittings Up to 4 Drill Guides for Gland Support

ENVIRONMENTAL

Water/Dust Tight Enclosure Type 4X & IP66
Operating Temperature -22° to +140°F (-30° to +60°C)
Storage Temperature range -22° to +140°F (-30° to +60°C)

COMPLIANCE

UL/CUL Class I, Division 2, Groups A, B, C and D
FCC Part 15¹, Class A
ICES-003 CLASS A
IC CISPR 22: 2008
61000-6-2: 2005



¹ This device complies with Part 15 of the FCC Rules. Operation is subject to the following two conditions: (1) This device may not cause harmful interference, and (2) this device must accept any interference received, including interference that may cause undesired operation.

ORDERING INFORMATION

Warranty: Five years parts and labor

Order No.	Description
P5312	WTT-30-V-H Watertight Telephone/Metal Keypad/Curly Handset Cord
P5313	WTT-40-V-H Watertight Telephone/Metal Keypad/Armored Handset Cord
P5314	WTR-11-V-H Watertight Ringdown Telephone/Curly Handset Cord
P5315	WTR-41-V-H Watertight Ringdown Telephone/Armored Handset Cord

Options

CC Conformal Coated Circuit Board
NC Noise Canceling Microphone
LCK-WTE Locking Door
VR-WTE Vandal Resistant Faceplate Screws
Choice of enclosure colors*
Custom embossed logo or smooth face for label*
* minimum quantity required – consult with sales agent

Distributed by:



GUARDIAN TELECOM LTD.
Calgary, Alberta, Canada
Telephone: 403 258 3100 Facsimile: 403 255 2595
1 800 363 8010 (North America)
info@guardiantelecom.com | www.guardiantelecom.com

