

WTT WTR SERIES

Watertight Telephones

WTT WTR SERIES WATERTIGHT INDUSTRIAL ANALOG NON-HAZARDOUS TELEPHONES

- WTT-30 Watertight Telephone/Metal Keypad/Curly Cord
- WTT-40 Watertight Telephone/Metal Keypad/Armored Handset Cord
- WTR-11 Watertight Ringdown Telephone/Curly Cord
- WTR-41 Watertight Ringdown Telephone/Armored Handset Cord

FEATURES and BENEFITS

- Water/dust-tight thermoplastic resin enclosure, Type 4X & IP66
- Encapsulated circuitry impervious to moisture, dust and corrosion
- Waterproof connections & stainless steel fittings for longer life
- Corrosion protected and powder coated steel faceplate
- WTT models have metal keypads for extended life
- Magnetic reed hook switch to reduce parts subject to wear
- Surge arrestor to prevent voltage spike damage
- Vandal resistant armored handset cord with lanyard on WTT-40 & WTR-41 models
- Heavy duty G Type industrial handset
- Electret noise reducing microphone for clear communication
- Modular parts for easy service
- Integrated mounting feet
- Hearing aid compatible & receiver volume adjustment
- Electronic ringer for reliability
- Tone or pulse dialing on the WTT models offer universal configuration
- Easily connects to any single line analog CO or PBX telephone line
- WTR Ringdown offers a Auto Dialer option to provide user programmable numbers
- Lift the WTR-11 or WTR-41 handset and PBX programming or an optional autodialer routes the call to its assigned location
- Handset retainers to maintain on-hook status
- Spring loaded door
- Easy support drill guides for top & bottom mount glands

APPLICATIONS

Guardian's WTT & WTR telephone series are the top of the line telephones for use in the most extreme conditions such as:

All Outdoor Locations	Public Access Areas	Public Transit
Public Safety Purposes	Food Processing Plants	Sewage Plants
Highway Call Boxes	Outdoor Sporting Facilities	Parks
Construction Sites	Industrial Facilities	Tunnels
Parking Structures	University Campuses	Waterfronts
Greenhouses	Plant Entry Gates	and more ...

INSTALLATION and CONNECTABILITY

To provide flexibility and the potential for growth, Guardian telephones are easily and economically connected to any telephone network by standard wiring and components. Voice quality is unaffected when phones are connected within 15,000 feet (~4,600 meters) of a main telephone switch accepting single line telephones. Maintaining safety standards may require use of wiring conduits or other considerations. WTT telephones are tone/pulse switchable. Initial settings are to tone prior to delivery (unless requested otherwise). In-service switching may require technical assistance.

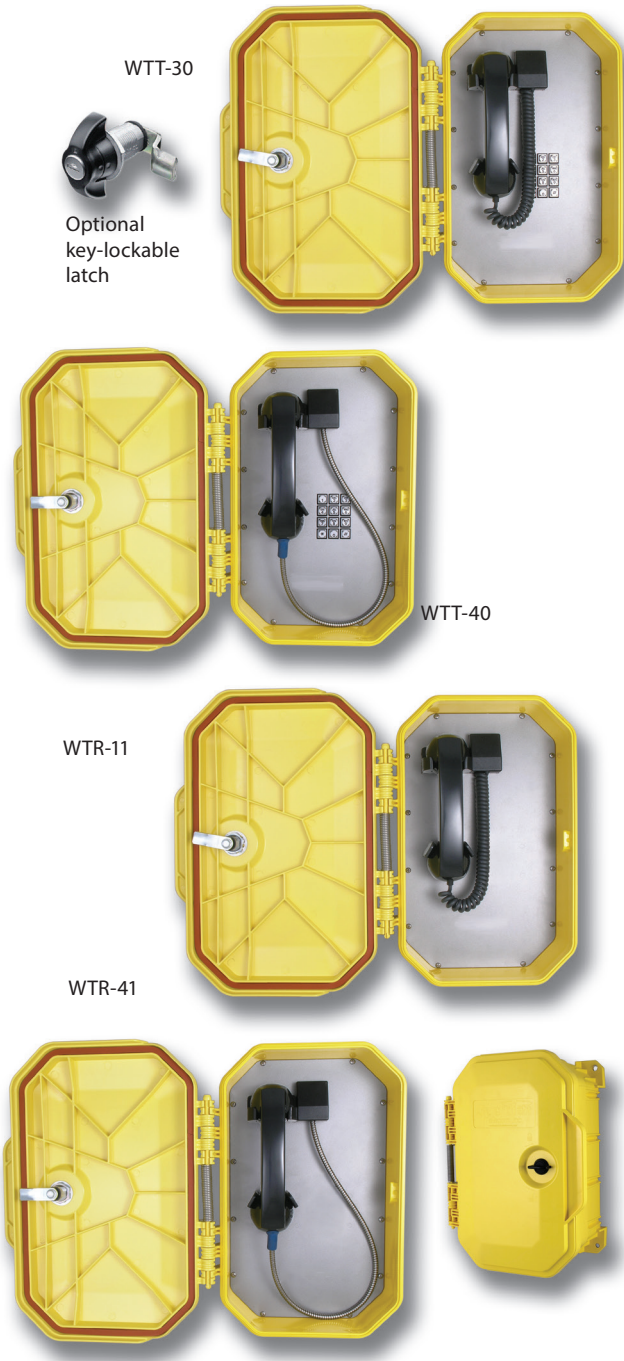

WTT WTR SERIES

Guardian's WTT/WTR SERIES Water Tight Industrial Telephone Series offer maximum efficiency under extreme environmental conditions. The sturdy thermoplastic resin enclosure protects the internal circuitry against wind blown dust, rain, corrosion, splashing and high pressure water. With Type 4X & IP66 ratings these are ideal telephones for harsh conditions.



tough. trusted. true.



OVERALL DIMENSIONS

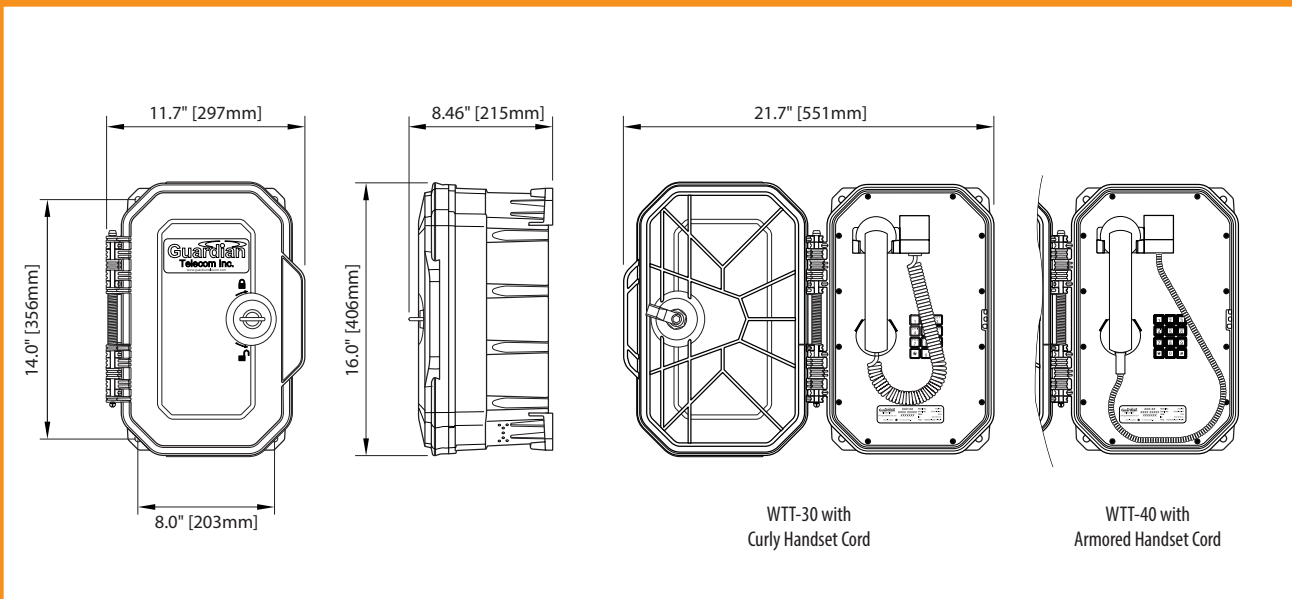

WTT-30 & WTT-40 Watertight Telephones • WTR-11 & WTR-41 Watertight Ringdown Telephones

ENGINEERING SPECIFICATIONS

ELECTRICAL PERFORMANCE

Audio Range Frequency Response	300 - 3400 Hz
Dialing Method (WTT-30/40)	DTMF or 40/60 Pulse @10 PPS
Transmit Objective Loudness Rating (TOLR)	Nominal -38 +/- 3 dB
Receiver Volume Adjustment	3 steps up / 2 steps down 8.1dB / 5.1 dB
Receiver Objective Loudness Rating (ROLR)	Nominal 50 +/- 3 dB
- receiver volume at maximum	41.9 +/- 3 dB
- receiver volume at minimum	55.4 +/- 3 dB
Side Tone Objective Loudness Rating (SOLR)	Nominal 11 +/- 4 dB
- receiver volume at maximum	7 +/- 4 dB
- receiver volume at minimum	14 +/- 4 dB
Ringer Output	85 dB
FCC Ringer Equivalence	0.8 B
Set Impedance	600 Ohms Nominal
Maximum Loop	15Kft (~4,600m) of 22 AWG Wire

ELECTRICAL REQUIREMENTS

Ringer Sensitivity	40 -100 V, 16 - 25 Hz
Line Voltage	24 - 56 VDC
Loop Current	20 - 120 mA
Connection Method	Fuse

MECHANICAL SPECIFICATIONS

Hook Switch (Cradle Switch) Life	>1 000 000 Operations
Body Construction	Thermoplastic Resin
Faceplate	Corrosion Protected & Powder Coated
Net Weight	11.8 lbs (5.4 kg)
Shipping Weight	14.0 lbs (6.3 kg)
Shipping Dimensions (L x W x D)	20.0" x 15.0" x 12.0" (508 x 381 x 305 mm)
Hand Set Construction	High Impact Polycarbonate
Mounting	Vertical Wall
Microphone	Noise Reducing Electret
Receiver	Hearing Aid Compatible
Hardware Material	Stainless Steel
Connection Fittings	Up to 4 Drill Guides for Gland Support

ENVIRONMENTAL

Water/Dust Tight Enclosure	Type 4X & IP66
Operating Temperature	-40° to +140°F (-40° to +60°C)
Storage Temperature	-58° to +176°F (-50° to +80°C)

Humidity	0 - 95% RH Non-Condensing
Dust Resistant	Full Gasket Faceplate

COMPLIANCE

CSA	Temperature Code T5
Industry Canada	1012-6721A
FCC	HQHCAN-22517-TE-E



ORDERING INFORMATION

Warranty: Five years parts and labor

Order No.	Description
P5301	WTT-30 Watertight Telephone/Metal Keypad/Curly Cord
P5302	WTT-40 Watertight Telephone/Metal Keypad/Armored Handset Cord
P5300	WTR-11 Watertight Ringdown Telephone/Curly Cord
P5303	WTR-41 Watertight Ringdown Telephone/Armored Handset Cord

Options	Description
NC	Noise Canceling Microphone
AD	Auto Dialer
LCK-WTE	Locking Door
VR-WTE	Vandal Resistant Faceplate Screws
Choice of enclosure colors*	
Custom embossed logo or smooth face for label*	
* minimum quantity required – consult with sales agent	

Distributed by:



GUARDIAN TELECOM LTD.
 Calgary, Alberta, Canada
 Telephone: 403 258 3100 Facsimile: 403 255 2595
 1 800 363 8010 (North America)
 info@guardiantelecom.com | www.guardiantelecom.com

