

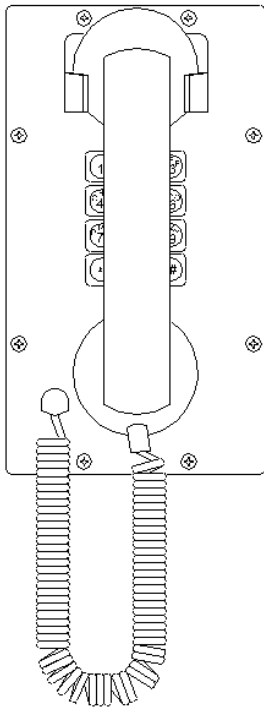

# Industrial Telephones

## SCT Series

### Installation & Operation



SCT-10

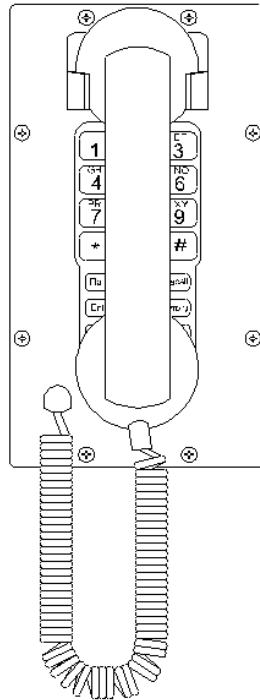

SCT-20

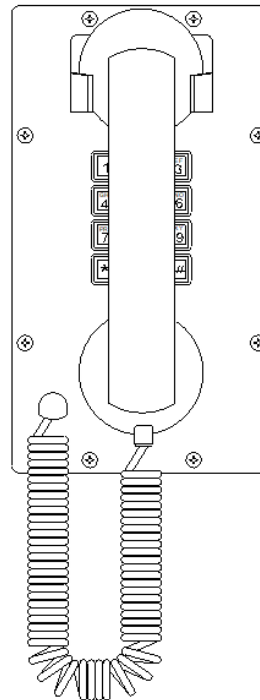

SCT-30

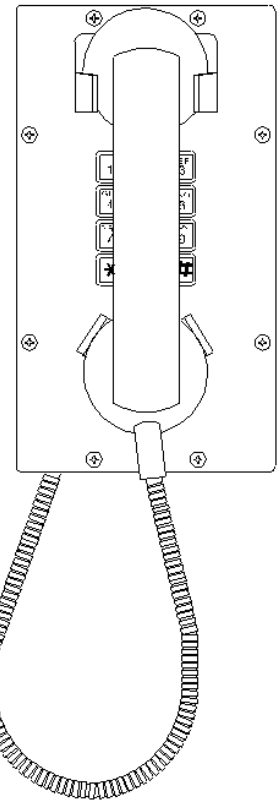

SCT-40

## Table of Contents

|   |    |
|---|----|
| Package Contents .....                                  | 2  |
| Overview .....  | 3  |
| Standard Features on All Models .....                   | 3  |
| Features (Specific Models) .....                        | 4  |
| Options Available .....                                 | 4  |
| Accessories .....                                       | 4  |
| Installing the SCT .....                                | 8  |
| Field Repairs .....                                     | 9  |
| Operation – Models with Standard Keypad .....           | 10 |
| Programming the SCT-20 with Multi-Function Keypad ..... | 10 |
| Operating the SCT-20 .....                              | 10 |
| Specifications .....                                    | 11 |
| Replacement Parts .....                                 | 12 |
| Government Certification .....                          | 13 |
| Warranty .....  | 14 |
| Disclaimer .....  | 14 |
| Warning .....   | 14 |
| Service Telephone Number .....                          | 14 |
| Feedback .....  | 14 |
| Guardian Product Return .....                           | 15 |
| Cleaning Tips for Guardian Telephones .....             | 16 |
| Storage .....   | 16 |

## Table of Figures

|   |   |
|---|---|
| Figure 1 - Features .....                 | 5 |
| Figure 2 - Dimensions (Typical) .....     | 6 |
| Figure 3 - Installation SCT-10 & 30 ..... | 6 |
| Figure 4 - Installation SCT-20 .....      | 7 |
| Figure 5 - Installation SCT-40 .....      | 7 |

## Package Contents

(1) SCT Telephone

|  |  |
|--|--|
|  <p>GENERAL ALERT<br/>ALERTE GÉNÉRALE</p> | <p><b>Warning</b></p> <p><i>Electrical Hazard:</i> Wiring connections for this product should be made by a licensed electrician or trades person according to all applicable electrical and building codes.</p> <p><b>Avertissement</b></p> <p>Danger électrique : Les connexions de câblage de ce produit doivent être effectuées par un électricien agréé ou une personne de métier selon tous les codes électriques et du bâtiment applicables.</p> |
|--|--|

## Overview

### ***SCT Series Industrial Telephones***

SCT telephones are designed to provide safe, reliable communication in areas prone to high humidity, chemical vapors, dust and physical abuse. Several variations and options are available to suit the end user's requirements.

### **Standard Features on All Models**

#### ***Enclosure***

- 16 Gauge steel, zinc dichromate plated and powder coated

#### ***Encapsulated Circuitry***

- circuit boards are resistant to corrosive agents (e.g. H<sub>2</sub>S, SO<sub>2</sub> and NH<sub>3</sub>), and environments with high humidity

#### ***Surge Arrestor***

- protects the user in the event of a high voltage spike on the telephone line

#### ***Fuse***

- prevents damage to the electronic circuits in the event of a high voltage spike on the telephone line

#### ***Magnetic Reed Hook Switch***

- no moving parts

#### ***Tone (DTMF) Operation***

- factory set to tone (DTMF) dialing
- pulse dialing can be ordered or configured in the field

#### ***4' Heavy Duty Handset Cord (Not Available With SCT-40)***

- withstands severe use

#### ***Hearing-Aid Compatible (HAC)***

- compatible with inductively coupled hearing-aid devices

#### ***Receiver Volume Control***

- Switches in handsets, (on keypad of SCT-20), provide 13.5dB of range.

### Features (Specific Models)

**P6960 SCT-10**

- Waterproof 3 x 4 Keypad
- Receiver volume control buttons on handset

**P6270 SCT-20**

- Membrane Keypad With Features
  1. weather tight
  2. 10 number memory
  3. Redial - last number (31 digits)
  4. Recall - obtains dial tone without hanging up handset
  5. Flash - 600ms timed loop break
  6. Pause - 3 second pause in programming
  7. Mute - disables handset microphone
  8. Softer/Louder – 2.7dB steps (+8.1dB/-5.4dB 3 steps up, 2 steps down)

**P6268 SCT-30**

- Metal 3 x 4 Keypad
- Receiver volume control buttons on handset

**P6972 SCT-40**

- Metal 3 x 4 Keypad
- 22" Armored Handset Cord
- Handset Retainer Clips
- Receiver volume control buttons on handset

| <b>Options Available</b>   |        |                |
|----------------------------|--------|----------------|
| 20' Heavy Duty Coil Cord   | (20C)  | SCT-20 Only    |
| 20' Heavy Duty Coil Cord   | (20VC) | SCT-10/30 Only |
| Noise Canceling Microphone | (NC)   |                |

### Accessories

- P7225 Weatherproof ring detect relay
- P7232 Weatherproof off-hook detect relay
- Loud Ringers
- Strobe Lights

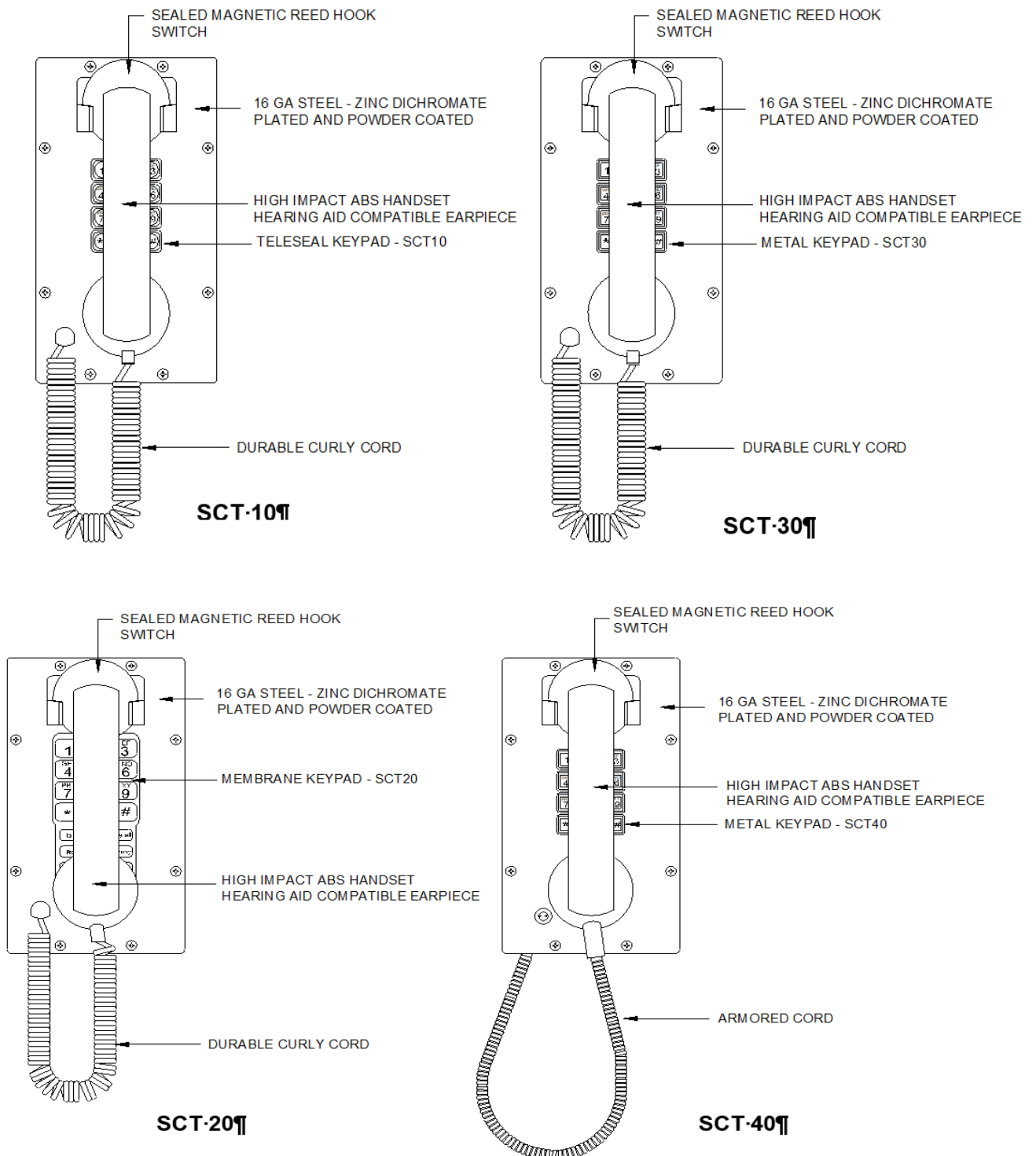

**Figure 1 - Features**

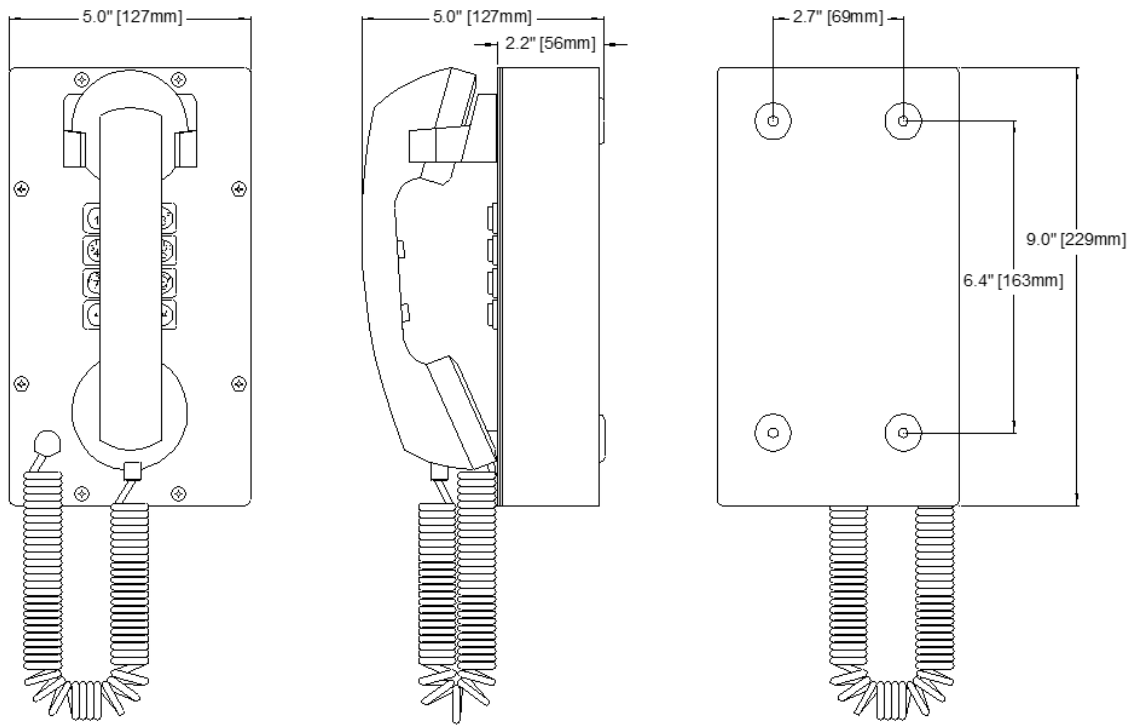

**Figure 2 - Dimensions (Typical)**

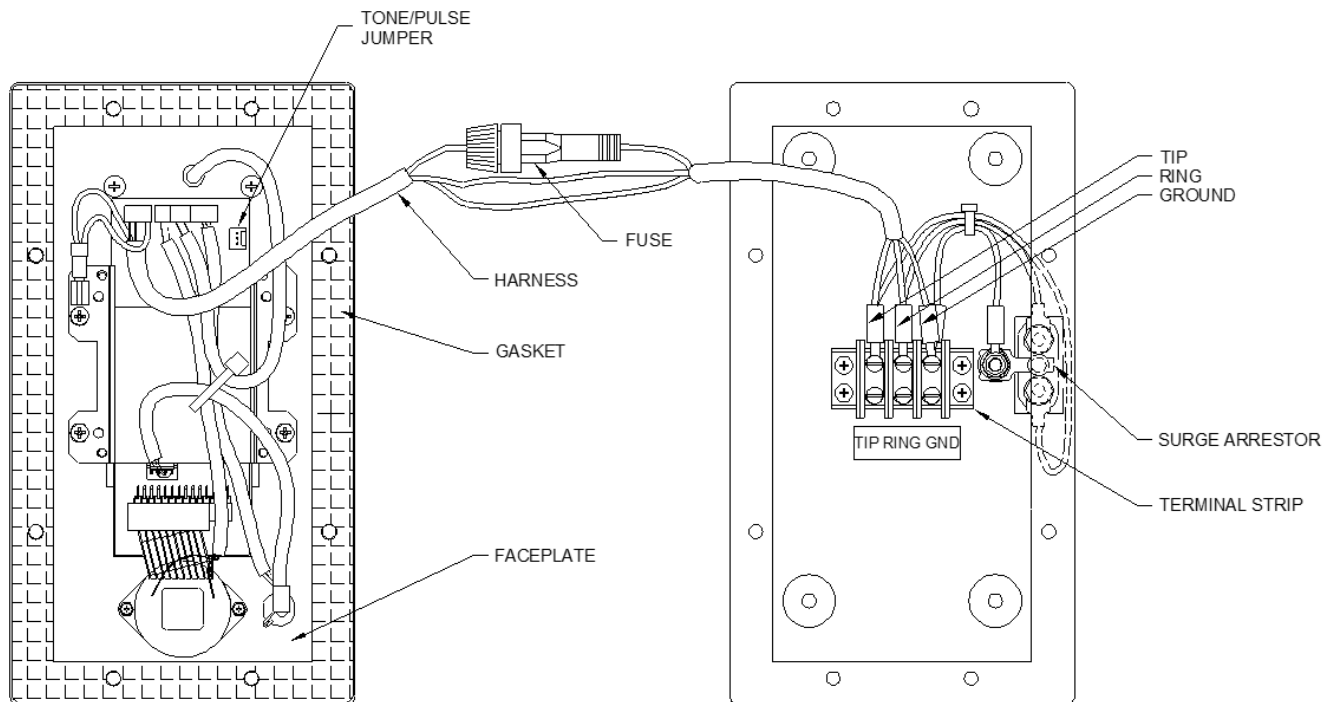

**Figure 3 - Installation SCT-10 & 30**

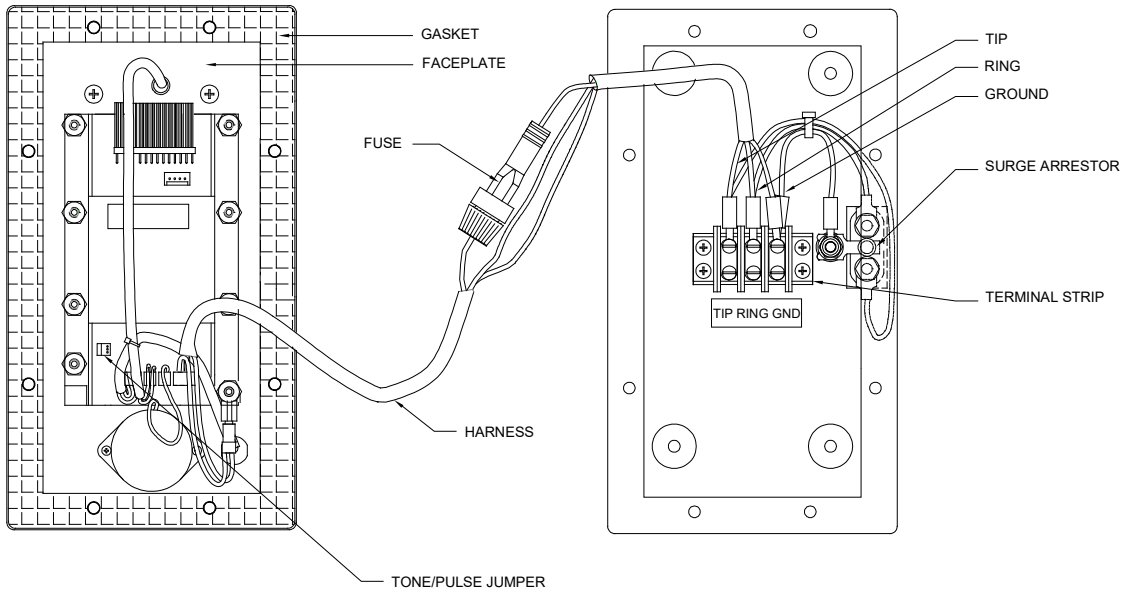

**Figure 4 - Installation SCT-20**

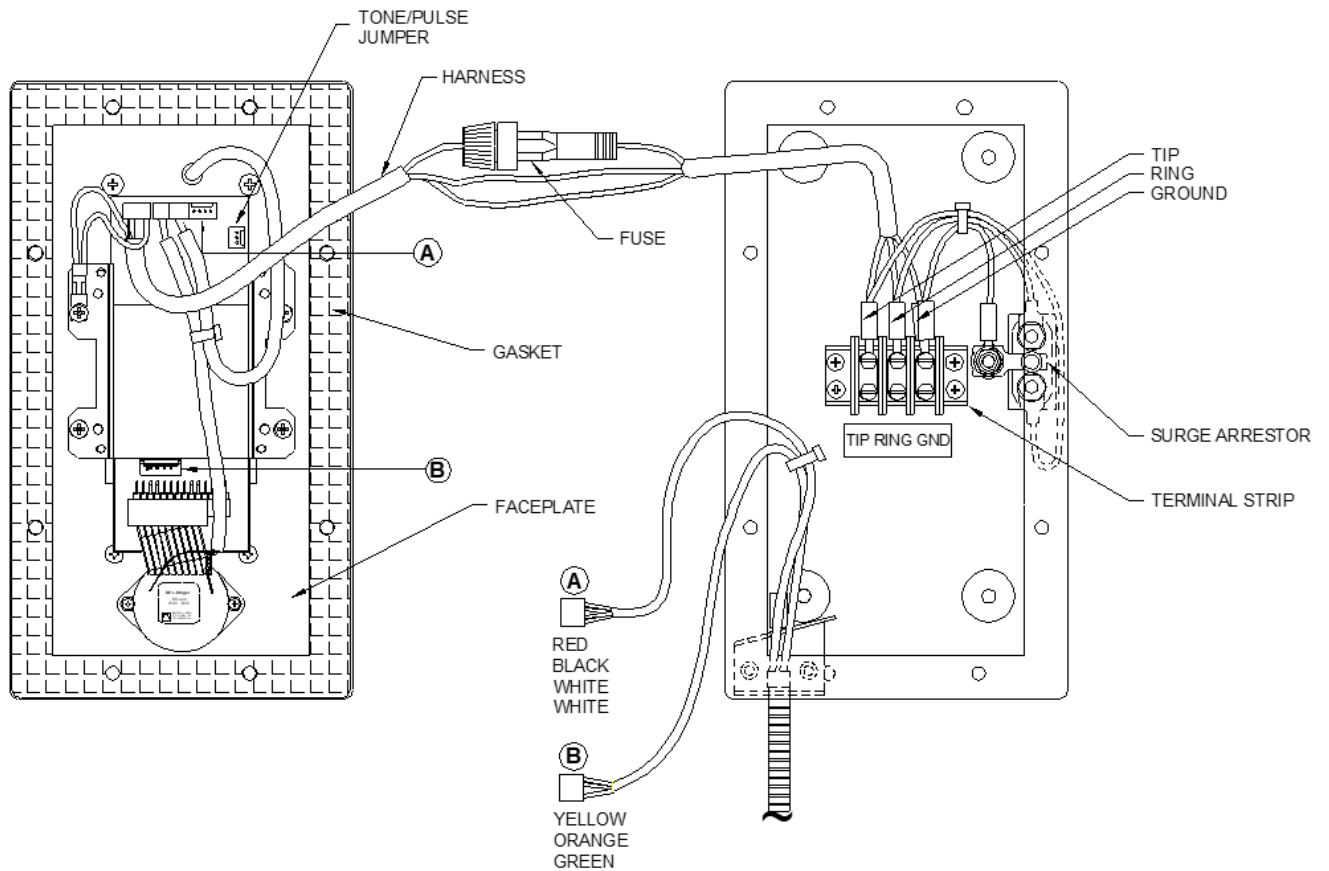

**Figure 5 - Installation SCT-40**

### Installing the SCT

- Follow all appropriate electrical codes and use only approved electrical fittings for the installation.
- Choose a wall location that is free of obstructions and permits space for cable or conduit runs.
- Ensure mounting can support 4lbs (1.8kg) and any additional foreseeable load.
- Ensure that none of the electrical connection circuits are live.
- Remove the eight (8) cover screws from the front of the unit and carefully remove the front cover assembly. NOTE that the handset and all electronics are attached to the front plate. The front cover may be separated from the back box by disconnecting the harness plugs.

#### **To change the Tone/Pulse setting to pulse, if required:**

- Move the jumper from pins 1 & 2 of the Tone/Pulse connector to pins 2 & 3.
- To change the setting back to tone move the jumper back to pins 1 & 2.
- Use the template provided to locate and drill holes for #8 or M4 mounting screws.
- Attach the back box to the wall. If weather resistance is important in your application select washers that will assist in sealing the mounting holes.

#### **Wiring the SCT to the Telephone System**

- Fit an appropriate cable gland, grommet or conduit connector to the 7/8" opening in the bottom of the enclosure.
- Bring cable into the enclosure through the opening and attach individual wires from the exchange (Tip/Ring/Ground) to the connector (Tip & Ring are not polarity sensitive). If a conduit hub is used, ensure it is grounded to the ground stud.
- Ensure all connections are tight, then replace and secure the cover.
- Connect the telephone into the system.
- Test the unit by calling to and from another unit on the exchange.

*See: Figure 2 -  
Dimensions*

*Tip: The SCT is factory  
preset for DTMF tone.*

*See: Figure 3 -  
Installation SCT-10 & 30  
& Figure 4 - Installation  
SCT-20*

*Tip: Use #8 or M4  
screws to secure the unit  
to the wall.*

*See: Figure 3 -  
Installation SCT-10 & 30  
& Figure 4 - Installation  
SCT-20*



### Field Repairs

Field repairs may only be carried out by qualified technicians using OEM parts. Substitution of parts voids warranty and may pose a hazard to users of the equipment.

*See: Replacement Parts*

- Disconnect the telephone from Tip and Ring power supplied by the PABX or central office before attempting to make repairs.
- Carefully remove the front cover assembly and separate from the housing by disconnecting the harness plugs. NOTE that the handset and all electronics are attached to the front plate.
- Perform the necessary repairs or adjustments.
- Carefully replace the front plate and install all eight screws. Do not over tighten the cover screws; there is a flexible gasket between the cover and the body. Excessive tightening of the screws deforms the gasket and reduces the weather resistance of the set.

*See: Figure 3 -  
Installation SCT-10 & 30  
& Figure 4 - Installation  
SCT-20*

### Fuse Replacement

- Remove the old fuse by pushing in the end cap of the fuse holder and turning counterclockwise to open. Insert a new 0.25 amp, 250Volt, 3AG fast blow fuse and close the fuse holder.

### WARNING!

- Replace only with a 0.25 amp 250V 3AG fast blow fuse. Failure to do so will void the warranty.
- If, on reconnecting power, the fuse fails, check the telephone system wiring. The fuse protects the Tip and Ring line from the telephone system. It is usually powered at 48 volts DC and must not be connected to 120 volts AC.

### Changing the Tone/Pulse Setting

- Set the Tone/Pulse jumper for the desired operation. For pulse, set the jumper between the center pin and the "P", for tone set it between the center pin and "T".

*See: Figure 3 -  
Installation SCT-10 & 30  
& Figure 4 - Installation  
SCT-20*

### Operation – Models with Standard Keypad

- Once the standard Model SCT Telephone has been properly installed and energized operation is identical to most other single line telephones.
- Adjust the receiver volume using the buttons on the handset.

### Programming the SCT-20 with Multi-Function Keypad

A direct memory access register can be assigned to each of the 10 number keys.

Each direct memory access register can contain up to 20 characters.

- Lift the telephone handset off the hook.
- Press **Program** to put the phone into programming mode.
- Press **Memory**.
- Press a number key **0-9**.
- Enter the telephone number you want to store (e.g., 1-800-363-8010).
  - N.B. valid entries are **0-9**, **\***, **#**, and **Pause**
- If your phone requires you to dial 9 (or other digit) to access an outside line, press the **9** key, then the **Pause** key, then enter the telephone number you want to store (e.g., 1-800-363-8010).
- Press **Program** again to leave programming mode and return to normal telephone operation.

*Tip: Valid characters are 0-9, \*, # and Pause.*

*Tip: The number selected is assigned to the access register.*

*Tip: You can store up to 10 numbers in memory.*

### Operating the SCT-20

#### **Manual Operation:**

- Lift the handset and dial manually.
- Hang up the handset at the end of conversation.

#### **Automatic Memory Dialing: For Model SCT-20 with Optional Multi-function Keypad**

- Lift the handset.
- Press **Memory**.
- Press a number key **0-9**.
- The number stored in the register will automatically dial.
- Adjust the receiver volume using the buttons on the keypad.

*Tip: Valid keys for manual dialing are 0-9, \* and #.*

*Tip: Program the SCT to use this quick dialing method.*

| <b>Specifications</b>                      |                                      |
|--|--------------------------------------|
| <b><i>Electrical Performance</i></b>       |                                      |
| AUDIBLE RANGE FREQUENCY RESPONSE           | 300 – 3400 Hz                        |
| DIALING METHOD                             | DTMF OR 40/60 PULSE AT 10 PPS        |
| TRANSMIT OBJECTIVE LOUDNESS RATING (TOLR)  | -38 +/- 3 dB                         |
| RECEIVER VOLUME ADJUSTMENT                 | +8.1 / -5.4 dB IN 5 STEPS OF 2.7 dB  |
| RECEIVE OBJECTIVE LOUDNESS RATING (ROLR)   |                                      |
| -AT NOMINAL VOLUME LEVEL                   | 50 +/- 3 dB                          |
| -AT MAXIMUM VOLUME LEVEL                   | 41.9 +/- 3 dB                        |
| -AT MINIMUM VOLUME LEVEL                   | 55.4 +/- 3 dB                        |
| SIDE TONE OBJECTIVE LOUDNESS RATING (SOLR) |                                      |
| -AT NOMINAL VOLUME LEVEL                   | 11 +/- 4 dB                          |
| -AT MAXIMUM VOLUME LEVEL                   | 7 +/- 4 dB                           |
| -AT MINIMUM VOLUME LEVEL                   | 14 +/- 4 dB                          |
| MEMORY DIAL (SCT-20 ONLY)                  | 10 REGISTERS OF 20 DIGITS EACH       |
| FLASH ( " )                                | 600 M SEC TIMED DISCONNECT           |
| MUTE ( " )                                 | PRESS KEY TO MUTE TRANSMITTER        |
| REDIAL ( " )                               | 31 DIGITS MAXIMUM                    |
| RINGER OUTPUT                              | >85 dB                               |
| FCC RINGER EQUIVALENCE                     | 0.8B                                 |
| SET IMPEDANCE                              | 600 OHMS NOMINAL                     |
| MAXIMUM LOOP                               | 15,000 FT (4,600 M) OF 22 AWG COPPER |
| <b><i>Electrical</i></b>                   |                                      |
| RINGER SENSITIVITY                         | 40 – 100 V, 16 – 25 Hz               |
| LINE VOLTAGE                               | 24 – 56 VDC                          |
| LOOP CURRENT                               | 20 - 120 mA                          |
| CONNECTION METHOD                          | TERMINAL BLOCK                       |
| FUSE                                       | ¼ AMP 250 VOLT 3AG FAST BLOW         |
| <b><i>Environmental</i></b>                |                                      |
| WEATHERPROOF                               | ENCLOSURE NEMA 3R                    |
| TEMPERATURE                                | -40° TO +60° C (-40° TO +140° F)     |
| HUMIDITY                                   | 0 TO 95% RH                          |
| DUSTPROOF                                  | FULLY GASKETED ENCLOSURE             |

| <b>Mechanical</b>                |   |
|----------------------------------|---|
| HOOK SWITCH (CRADLE SWITCH) LIFE | >1 000 000 OPERATIONS                               |
| BODY CONSTRUCTION                | 16 GA STEEL, ZINC DICHROMATE PLATED & POWDER COATED |
| OVERALL DIMENSIONS (H X W X D)   | 9.0 X 5.0 X 5.0 INCHES (229 X 127 X 127 MM)         |
| NET WEIGHT                       | 4 LBS (1.8 KG)                                      |
| SHIPPING DIMENSIONS              | 15 X 11.5 X 5.0 INCHES (381 X 293 X 127 MM)         |
| SHIPPING WEIGHT                  | 6 LBS (2.7 KG)                                      |
| HANDSET MATERIAL                 | HIGH IMPACT ABS                                     |
| MICROPHONE                       | NOISE REDUCING ELECTRET                             |
| OPTIONAL MICROPHONE              | NOISE CANCELING DYNAMIC                             |
| RECEIVER                         | HEARING AID COMPATIBLE                              |
| STANDARD MOUNTING                | VERTICAL WALL                                       |
| WIRING ACCESS                    | 7/8" DIAMETER OPENING FOR OWNER SUPPLIED FITTING    |
| HARDWARE MATERIAL                | STAINLESS STEEL                                     |
| <b>Compliance</b>                |   |
| INDUSTRY CANADA                  | 1012 6721 A   |
| FCC                              | HQHCAN-22517-TE-E                                   |

### Replacement Parts

| <b>Part No.</b> | <b>Description</b>   | <b>Field Replaceable</b> |
|-----------------|--|--------------------------|
| P000907         | Keypad Cover – Teleseal For SCT-10                             | No                       |
| P002657         | Handset Assembly C/W 4' Coil Cord For SCT-20                   | Yes                      |
| P002782         | Ringer – Floyd Bell BR-3-39                                    | Yes                      |
| P002786         | Handset Cradle   | Yes                      |
| P002787         | Gasket – Faceplate   | Yes                      |
| P002837         | Faceplate SCT-10 & SCT-30                                      | No                       |
| P002991         | Fuse – Glass 0.25 Amp 250V                                     | Yes                      |
| P002992         | Surge Arrestor – TII 126L1                                     | Yes                      |
| P003037         | Faceplate SCT-20   | No                       |
| P004150         | Housing  | No                       |
| P004371         | Handset Retainer – SCT-40 Only                                 | Yes                      |
| P005391         | Handset Assembly C/W 4' Coil Cord For SCT-10 & SCT-30          | Yes                      |
| P005543         | Faceplate SCT-40   | No                       |
| P005582         | Telephone Circuit Board  | Yes                      |
| P005699         | Handset Assembly C/W 22" Armored Cord For SCT-40               | Yes                      |
| P005786         | Plastic Keypad Assembly C/W Telephone Circuit Board For SCT-10 | Yes                      |
| P005917         | Reed Switch  | No                       |
| P006295         | Keypad – Metal For SCT-30 & SCT-40                             | Yes                      |
| P006517         | Keypad – Plastic For SCT-10                                    | Yes                      |

## Government Certification

Attached to the telephone are labels for *Industry Canada* and the *United States Federal Communications Commission*. These identify equipment certifications indicating the 60 and 70 series telephones meet certain telecommunications network protective, operational and safety requirements. These agencies do not guarantee the equipment will operate to the user's satisfaction.

Before installing this telephone equipment, users should ensure it is permissible to connect the equipment to facilities of the local telecommunications company.

Equipment must be installed using acceptable connection methods. In some cases, the telephone users inside wiring, associated with a single line service, may be extended by a certified connector assembly (telephone extension cord). The customer should be aware that in some situations compliance with the above conditions may not prevent degradation of service.

Repairs to certified equipment should be made by a supplier designated authorized maintenance facility.

For their own protection users should ensure the electrical ground connections of the power utility, telephone lines and internal metallic water pipe systems, if present, are connected. This precaution may be particularly important in rural areas.

**CAUTION:** Users should not attempt to make ground connections, but should contact the appropriate electrical inspection authority or electrician.

### **Load Number (LN)**

The Load Number (LN) assigned to each terminal device denotes the percentage of the total load to be connected to a telephone loop used by the device. Termination on a loop may consist of any combination of devices subject only to the requirement that the total of the Load Numbers of all the devices does not exceed 100.

### **Notification to Telephone Company**

Upon request, the customer must notify the telephone company of the particular line to which the connection will be made and provide the Industry Canada or FCC registration number. The local telephone company may request disconnection of the telephone where alterations or malfunctions affect the telephone's performance.

### **United States Federal Communications Commission**

This equipment generates, uses and can radiate radio frequency energy, and if not installed and used in accordance with the instruction manual, may cause interference to radio communications. It has been tested and found to comply with the limits for Class A computing device pursuant to Subpart J of Part 15 of FCC rules, which are designed to provide reasonable protection against such interference when operated in a commercial environment. Operation of this equipment in a residential area is likely to cause interference in which case the user, at his own expense, will be required to take whatever measures may be required to correct the interference.

### **Interference**

There is no guarantee that interference will not occur in a particular installation. If interference to radio or television reception from this equipment is suspected, proceed as follows:

1. Unplug the set, check for the interference.
2. Re-orient the receiving antenna.
3. Relocate the set with respect to the receiver.
4. Move the set away from the receiver.

If necessary, consult the supplier or an experienced radio/television technician for additional suggestions.

### **FCC Rules and Ringer Equivalence Number**

This equipment complies with Part 68 of the FCC Rules. On the side of this equipment is a label that contains, among other information, the FCC registration number and ringer equivalence number (REN) for this equipment. If requested, this information must be provided to the telephone company.

The REN is used to determine the quantity of devices which may be connected to the telephone line. Excessive RENs on the telephone line may result in the devices not ringing in response to an incoming call. In most, but not all areas, the sum of the RENs should not exceed five. To be certain of the number of devices that may be connected to the line, as determined by the total RENs, contact the telephone company to determine the maximum REN for the calling area.

### **Service changes and Limitations**

The telephone company may make changes in its facilities, equipment, operations, or procedures that could affect the operation of the equipment. If this happens, the telephone company will provide advance notice in order for you to make the necessary modifications in order to maintain uninterrupted service.

This equipment cannot be used on public coin telephone service as provided by your telephone company. Connection to party line service is subject to state tariffs (contact the state public utility commission, public service commission or corporate commission for information.)

### **Warranty**

Guardian Telecom, a division of Circa Enterprises Inc. warrants that its products are free from defective workmanship and materials. Guardian Telecom will, within three years from the date of final sale to the customer, replace or repair any such products provided they are returned to our facilities for examination. Freight costs (including brokerage if applicable), both to and from Guardian, are the sole responsibility of the customer. This warranty does not extend to any items that are deemed to have been misused, modified, neglected, improperly specified, improperly installed, or used in violation of instructions or specifications approved by Guardian Telecom. Guardian Telecom, a division of Circa Enterprises Inc. shall not be liable for incidental or consequential damage of any kind caused by any defect in our product. The total liability shall not, under any circumstances, exceed the purchase price of the products furnished by Guardian Telecom, a division of Circa Enterprises Inc.

***A return authorization must be obtained prior to warranty claims or repairs.***

### **Disclaimer**

The products covered by this manual are designed for use in Industrial Environments and/or Hazardous Locations. Due to the range of possible applications for these instruments, the manufacturer will not be responsible for damages or losses of any kind suffered as a result of the use of this product, including consequential damages.

### **Warning**

This device may be opened and reassembled by qualified personnel only, for the purposes of installing the product, making adjustments and replacing components, following the instructions in the product manual.

**High voltages may be present in this product when connected to telephone wiring.**

### **Service Telephone Number**

#### **1-800-363-8010**

Guardian Telecom provides a customer service telephone number that is toll-free within North America. If you need assistance when installing or operating this product, please call the toll-free telephone number between regular business hours (8:00AM-5:00PM), Mountain Standard Time. If you are calling outside of regular business hours, please leave a detailed message, and a member of Guardian Telecom's Service Department will return your call as soon as possible. If your product requires service, Guardian personnel will supply you with an RMA (return materials authorization) number over the telephone or through our web site product return page. This number must be included with your return address and the name of the person to contact.

**Guardian Telecom, a division of Circa Enterprises Inc.**

**Toll-free 1-800-363-8010**

**Ph. (403) 258-3100**

**Fax. (403) 255-2595**

**[www.guardiantelecom.com](http://www.guardiantelecom.com)**

### **Feedback**

Guardian Telecom continually strives to make reliable, durable, and easy to use products. If you, as an installer or user of our equipment, have any suggestions for improvements to this or any of our products or documents, including this manual, we would appreciate hearing from you.

| <b>Guardian Product Return</b>   |
|--|
| <p>Guardian products have been quality tested and are in full working order when shipped from the factory, given the rugged nature of these products shipping is not expected to damage a unit. In the unlikely event of a malfunction, Guardian follows the three-step procedure below.</p>   |
| <p><b><i>Step I - On-Site Correction</i></b></p>   |
| <ul style="list-style-type: none"> <li>• The most common source of difficulties with a new product is improper installation in one of two ways: incorrect wiring connections or connection to an incorrect power source.</li> </ul>  |
| <ul style="list-style-type: none"> <li>• Product wiring needs to be properly connected to the on-site wiring. Correct wiring instructions are shown in the user manual included with the product.</li> </ul>   |
| <ul style="list-style-type: none"> <li>• Connecting a telephone to a standard power source, rather than tip &amp; ring, will blow the telephone's internal, user-replaceable fuse. In the event of fuse burnout, disconnect the telephone from the power source, replace the fuse, and reconnect following the wiring diagrams provided with the product.</li> </ul>   |
| <p><b><i>Step II - Return Materials Authorization (RMA)</i></b></p>  |
| <ul style="list-style-type: none"> <li>• When a product has been installed following user manual instructions and the unit fails to operate, the user must contact Guardian Telecom to obtain authorization to return the product. This can be done by completing an RMA form online at <a href="https://www.guardiantelecom.com/support/rma/">https://www.guardiantelecom.com/support/rma/</a>, or by calling the service telephone number given in this manual.</li> </ul> |
| <ul style="list-style-type: none"> <li>• After providing information on the product, the owner and the nature of the problem, Guardian will issue a RMA number, to be shown on documentation returned with the product.</li> </ul>   |
| <ul style="list-style-type: none"> <li>• In addition to the RMA number, shipping documents should include name, address and telephone number of the owner along with contact information for the person responsible for the repair and/or the user who identified the malfunction.</li> </ul>  |
| <ul style="list-style-type: none"> <li>• (Where a product is being returned for repair from outside of Canada, customs documentation must show the product's serial number, date of export [date of purchase], and a notation that the equipment is: "Canadian goods returning.")</li> </ul>   |
| <p><b><i>Step III - Factory Authorized Service</i></b></p>   |
| <ul style="list-style-type: none"> <li>• Once received, each product is carefully inspected and tested. If the product is under warranty, repairs are completed and the product returned to the owner, generally within five working days of receipt by the factory.</li> </ul>  |
| <ul style="list-style-type: none"> <li>• A product that has been subjected to misuse, neglect or accident or is beyond the warranty period will be evaluated. The service department will provide the owner's representative with a repair cost estimate. Once approved, repairs are completed and the product returned, generally within five working days.</li> </ul>  |

### **Cleaning Tips for Guardian Telephones**

Guardian Telephones may occasionally need to be cleaned to maintain appearance. Generally, wiping the surface with a clean, water-dampened cloth will remove most films or residues. If the soiling is too stubborn for plain water, a mild detergent solution may be used. Be sure to wipe away any detergent residue with a plain water dampened cloth. The Telephone may be cleaned with any general-purpose household glass and surface type cleaner. Do not spray the telephone directly! Spray the cleaner on a soft cloth then wipe the surface. Pre-treated cloths such as those used for eyeglasses or cameras may be used to clean the Telephone. Premoistened towelettes may also be used, however, avoid those containing lanolin or aloe, as they will leave a slippery residue. The handset and surface of the telephone may be cleaned with disinfectants used for general cleaning in a medical environment. Isopropyl alcohol may be used applied with a cloth. Avoid using alcohol on silicon-based keypads, since doing so may significantly degrade legibility.

- Do not use furniture polishes, waxes or plasticizer-based cleaner (Armor All etc.)
- Do not use lanolin, aloe, glycerin or other skin care type products.
- Do not apply any solvent such as acetone, mineral spirits etc.
- Do not directly spray or immerse the handset.

### **Storage**

General Storage (All situations):

- Note any stacking limits or warnings on packaging (if any).
- Do not store in temperatures over +80C.
- Store in original packaging if possible until needed.

Long Term Storage (> 6 Months):

- If area is air-conditioned and not subject to high changes in humidity, continue to store in original packaging.
- If wide humidity shifts are expected, then use these steps:
  - Remove product from packaging (including plastic bags) and store on shelf in open air.
  - If area is subject to a high degree of dust, to help maintain cosmetic appearance you can cover with cloth (Do not cover with plastic or materials that will trap moisture) or clean periodically.
  - Do not store out of packaging long term where they are exposed to sunlight. Long-term exposure to UV may cause fading on plastic parts.





**THIS PAGE INTENTIONALLY LEFT BLANK**

**THIS PAGE INTENTIONALLY LEFT BLANK**



SAI GLOBAL  
ISO 9001:2015

**Guardian Telecom, a division of Circa Enterprises Inc.**

**Toll-free 1-800-363-8010**

**Phone (403) 258-3100**

**Fax. (403) 255-2595**

**[www.guardiantelecom.com](http://www.guardiantelecom.com)**

**E-mail: [sales@guardiantelecom.com](mailto:sales@guardiantelecom.com)**

*(Click to open message box)*

***Tough. Trusted. True.***

© Circa Enterprises 2020