

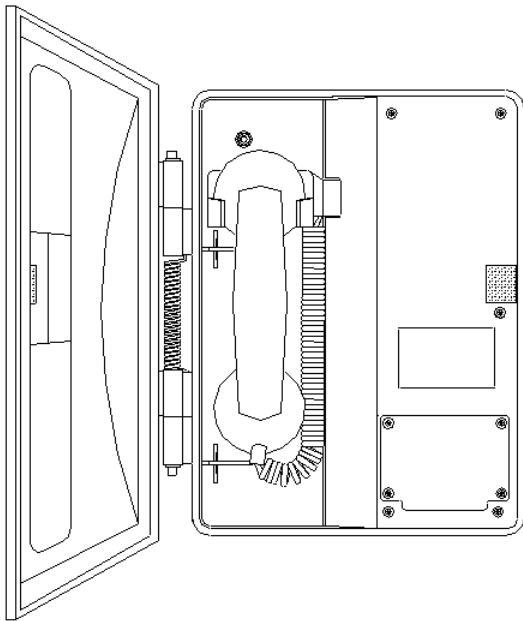

Weatherproof Industrial Ringdown Telephones

WRR Series Installation & Operation



WRR-11

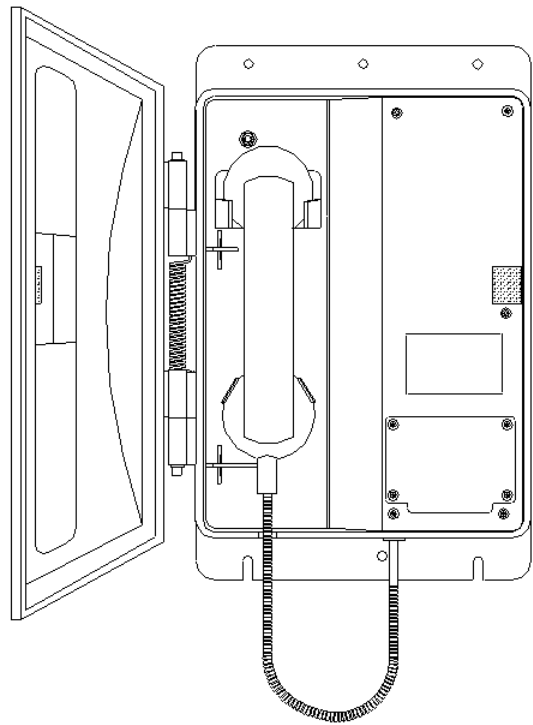

WRR-41

Table of Contents

Package Contents	2
Overview	3
Standard Features on All Models	3
Features (Specific Models)	4
Options Available	4
Accessories	4
Installing the WRR	7
Operating the WRR Series	8
Field Repairs	9
Specifications	10
Replacement Parts	11
Government Certification	12
Warranty	13
Disclaimer	13
Warning	13
Service Telephone Number	13
Feedback	13
Guardian Product Return	14
Cleaning Tips for Guardian Telephones	15
Storage	15

Table of Figures

Figure 1 - WRR-11 Features	5
Figure 2 - WRR-11 Overall Dimensions	5
Figure 3 - WRR-41 Features	6
Figure 4 - WRR-41 Overall Dimensions	6
Figure 5 - Tip & Ring Connection	8
Figure 6 - Fuse Replacement	9

Package Contents

(1) WRR Telephone



GENERAL ALERT
ALERTE GÉNÉRALE

Warning

Electrical Hazard: Wiring connections for this product should be made by a licensed electrician or trades person according to all applicable electrical and building codes.

Avertissement

Danger électrique : Les connexions de câblage de ce produit doivent être effectuées par un électricien agréé ou une personne de métier selon tous les codes électriques et du bâtiment applicables.

Overview

WRR Industrial Ringdown Telephone

The WRR is a rugged industrial telephone designed to provide safe, reliable, point-to-point communication in harsh environments such as refineries, mills, plants, warehouses, airports, ski hills or areas with high humidity.

The WRR Telephone may be supplied with an optional Auto Dialer or dialing may be programmed through a PABX. If an Auto Dialer is ordered with the WRR, refer to the manual for the Auto Dialer for instructions on programming and for compliances.

Standard Features on All Models

Enclosure

- weather tight, rugged Valox® & steel
- spring loaded hinged door

Faceplate

- 16 Gauge steel with wiring access to surge arrestor

Encapsulated Circuitry

- circuit boards are resistant to corrosive agents (e.g. H₂S, SO₂, and NH₃), and environments with high humidity

Surge Arrestor

- protects the user in the event of a high voltage spike on the telephone line

Fuse

- prevents damage to the electronic circuits in the event of a high voltage spike on the telephone line

Magnetic Reed Hook Switch

- no moving parts

4' Heavy Duty Handset Cord (WRR-11 only)

- withstands severe use

Anchored Armored Handset Cord (WRR-41 only)

- vandal resistant

Hearing-Aid Compatible (HAC) Receiver

- compatible with inductively coupled hearing-aid devices

Receiver Volume Control

- Switch in handset provides 13.5dB of range

Features (Specific Models)

P6076 Model WRR-11 Industrial Weather Resistant Ringdown Telephone

- 4 Coil Cord

P6077 Model WRR-41 Industrial Weather Resistant Ringdown Telephone

- 22" Armored Handset Cord
- Handset Retainer Clips
- Stainless Steel Mounting Plate

Options Available		
Stainless Steel Mounting Plate	(MP)	(Standard on WRR-41)
20' Heavy Duty Coil Cord	(20C)	(Not available with WRR-41)
Noise Canceling Microphone	(NC)	
Grey Enclosure	(GR)	
Autodialer P005156	(AD)	

Accessories

- P7224 Potted ring detect relay
- P7225 Weather Proof ring detect relay
- P7227 Potted off-hook detect relay
- P7232 Weather Proof off-hook detect relay
- PXXXX External Loud Ringer

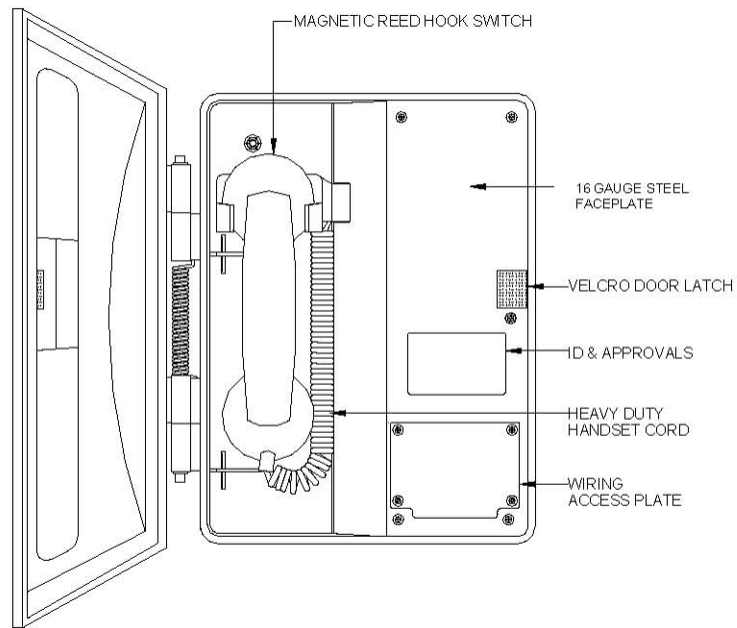

Figure 1 - WRR-11 Features

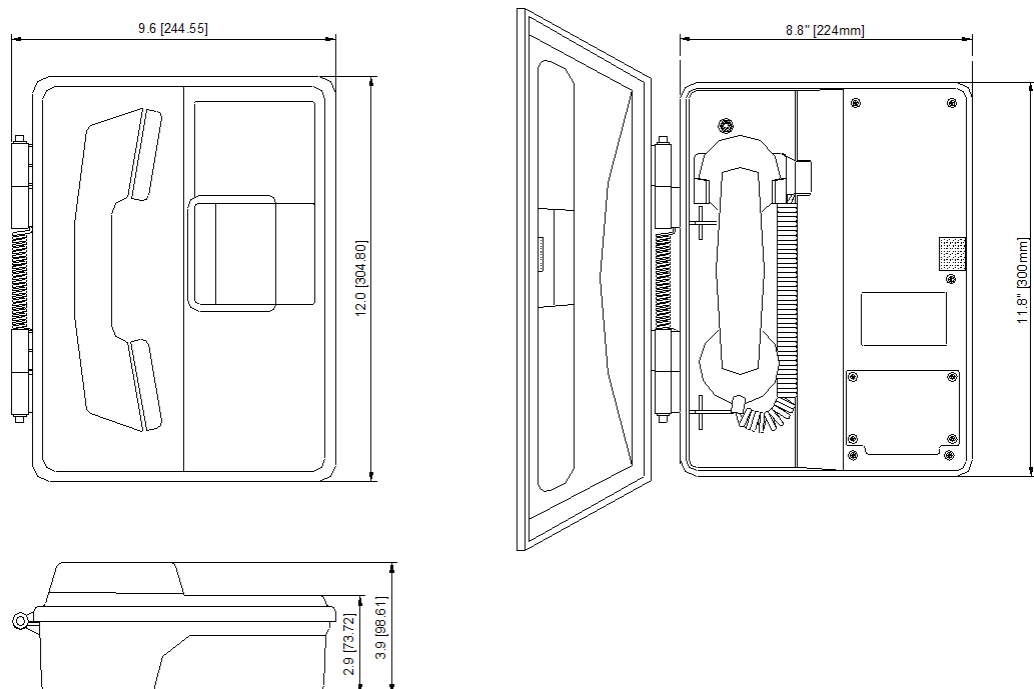

Figure 2 - WRR-11 Overall Dimensions

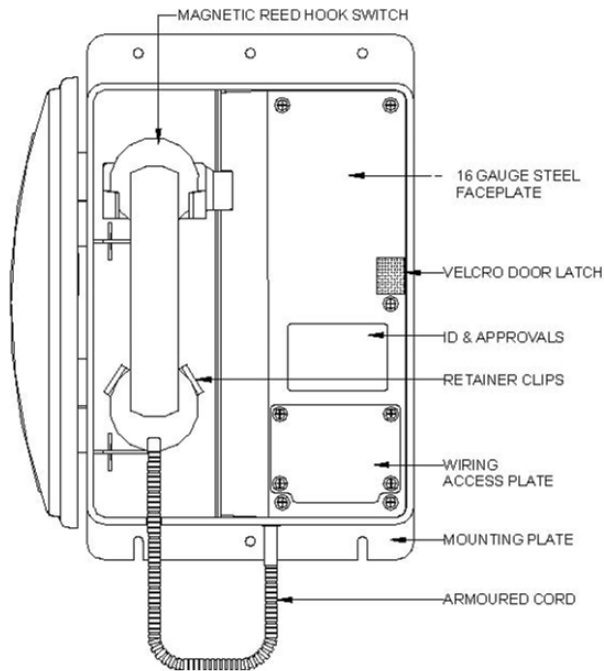

Figure 3 - WRR-41 Features

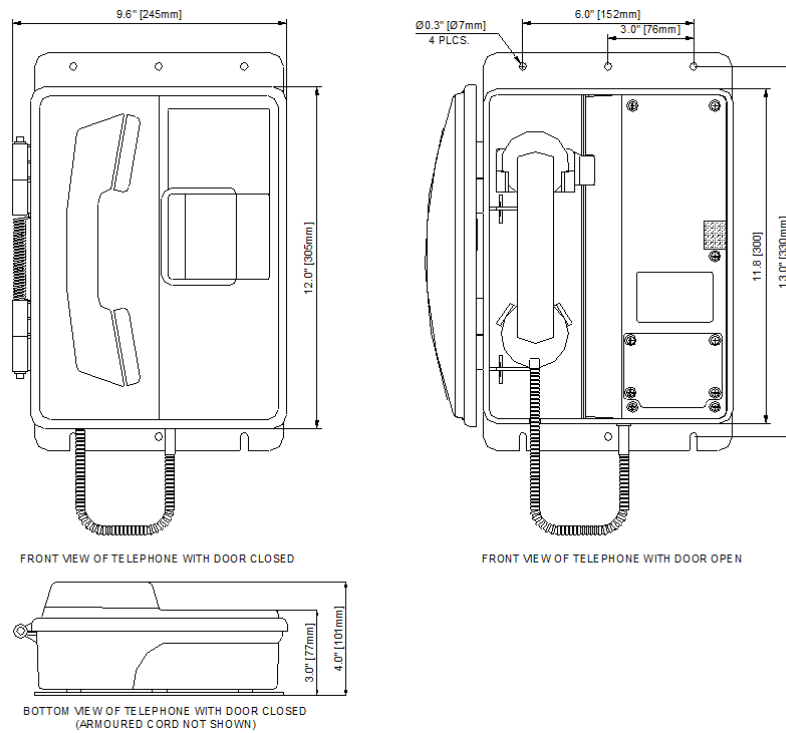

Figure 4 - WRR-41 Overall Dimensions

Installing the WRR

- Follow all appropriate electrical codes and use only approved electrical fittings for the installation.
- Choose a wall location that is free of obstructions and permits space for wiring.
- Ensure mounting can support 5.5 lbs (2.5 kg) plus any additional, foreseeable load.
- Ensure that none of the electrical connection circuits are live.

Mounting Without Optional Mounting Plate

- Use the appropriate template to locate and drill holes for mounting screws. The #10 screws provided require a 3 mm (1/8") hole for use in wood or similar materials. Use anchors in plaster or cement to provide a firm grip for the mounting screws. Use sturdy hollow-wall fasteners to mount the set to drywall.
- Loosen the five captive screws in the faceplate and swing the faceplate to the left. If the set is on a vertical surface, the faceplate will stay open like a book in this position. Take care not to disturb the internal wiring.
- Secure the unit to the wall.
- Replace the faceplate. Do not over tighten the screws.

Mounting With Optional Mounting Plate

- Use the appropriate template to locate and drill holes for mounting screws.
- Secure the unit to the wall.

Wiring the WRR to the Telephone System

- Remove the wiring access cover plate.
- Bring cable into the enclosure through the conduit entrance and attach individual wires from the exchange – Tip/Ring/Ground – to the surge arrester (Tip & Ring are not polarity sensitive). If a conduit hub is used, ensure it is grounded to the ground stud.
- Replace the wiring access cover plate.

Final Check

- Check the set visually for loose screws and trapped wires. Check that the handset hangs freely in the cradle and that the handset cord is not trapped by the door.
- Check that the faceplate is snug to its gasket, paying particular attention to the area around the cradle. Check that the door closes flush to the housing.
- The WRR Telephone may be supplied with an optional Auto Dialer or dialing may be configured by the PABX. If an Auto Dialer is ordered with the WRR, refer to the manual for the Auto Dialer for instructions on programming and for compliances.
- Test the unit by calling to and from another unit on the exchange.

See: Figure 2 - WRR-11 Overall Dimensions & Figure 4 - WRR-41 Overall Dimensions

See: Figure 2 - WRR-11 Overall Dimensions

Tip: Use #10 or M5 screws to secure the unit to the wall

Note: Ensure that connections are secure before replacing faceplate.

See: Figure 5 - Tip & Ring Connection

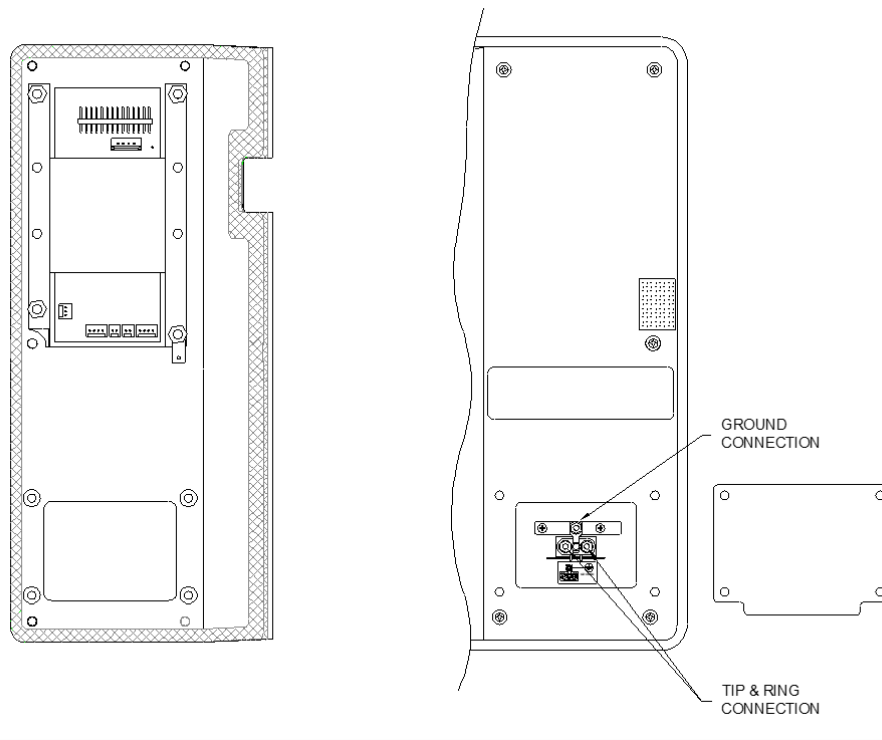

Figure 5 - Tip & Ring Connection

Operating the WRR Series

Lift the handset and the telephone will dial automatically.

When the call is completed, replace the handset in the cradle.

Field Repairs

Field repairs may only be carried out by qualified technicians using OEM parts. Substitution of parts voids warranty and may pose a hazard to users of the equipment.

- Disconnect the telephone from Tip and Ring power supplied by the PABX or central office before attempting repairs.
- Carefully remove the front cover assembly and separate from the housing by disconnecting the harness plugs. NOTE that the handset and all electronics are attached to the front plate.
- Perform the necessary repairs or adjustments.
- Carefully replace the front plate and install all eight screws. Do not over tighten the cover screws; there is a flexible gasket between the cover and the body. Excessive tightening of the screws deforms the gasket and reduces the weather resistance of the set.

Fuse Replacement

- Remove the old fuse by pushing in the end cap of the fuse holder and turning counterclockwise to open. Insert a new 0.25 amp, 250Volt, 3AG fast blow fuse and close the fuse holder.

WARNING!

- Replace only with a 0.25 amp 250V 3AG fast blow fuse. Failure to do so will void the warranty.
- If, on reconnecting power, the fuse fails, check the telephone system wiring. The fuse protects the Tip and Ring line from the telephone system. It is usually powered at 48 volts DC and must not be connected to 120 volts AC.

See: *Replacement Parts*

Note: *Ensure that connections are secure before replacing faceplate.*

See: *Figure 6 - Fuse Replacement*

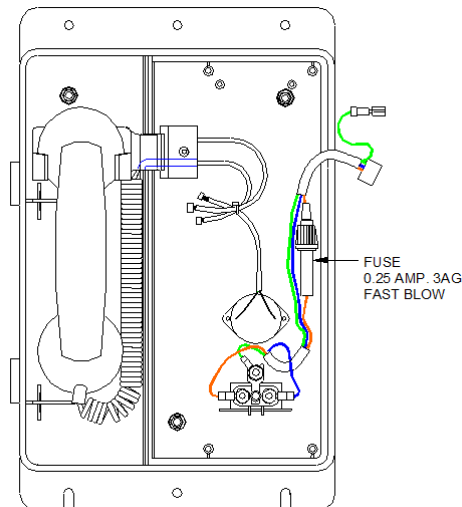

Figure 6 - Fuse Replacement

Specifications	
<i>Electrical Performance</i>	
AUDIBLE RANGE FREQUENCY RESPONSE	300 – 3400 Hz
TRANSMIT OBJECTIVE LOUDNESS RATING (TOLR)	-41 +/- 4 dB
RECEIVE OBJECTIVE LOUDNESS RATING (ROLR)	TYPICAL 50 +/- 3 dB
SIDE TONE OBJECTIVE LOUDNESS RATING (SOLR)	TYPICAL 11 +/- 4 dB
RINGER OUTPUT	>80 dB
FCC RINGER EQUIVALENCE	0.8A
SET IMPEDANCE	600 OHMS NOMINAL
MAXIMUM LOOP	15,000 Ft (4,600 M) OF 22 AWG COPPER
<i>Electrical Requirements</i>	
RINGER SENSITIVITY	40 – 100 V, 16 – 25 Hz
LINE VOLTAGE	24 – 56 VDC
LOOP CURRENT	20 - 120 mA
CONNECTION METHOD	SURGE ARRESTOR / TERMINAL BLOCK
FUSE	¼ AMP 3AG FAST BLOW
<i>Environmental</i>	
WEATHERPROOF	ENCLOSURE NEMA 3R
TEMPERATURE	-40° TO +140° F (-40° TO +60° C)
HUMIDITY	0 TO 95% RH
DUSTPROOF	FULLY GASKETTED ENCLOSURE
CORROSION RESISTANT	MIL-STD-810E SALT FOG
<i>Mechanical</i>	
HOOK SWITCH (CRADLE SWITCH) LIFE	>1 000 000 OPERATIONS
BODY CONSTRUCTION	GE VALOX 357 ^R ENGINEERING POLYMER
DIMENSIONS (H X W X D)	14 X 9.7 X 3.9 INCHES (356 X 246 X 99 MM)
NET WEIGHT	5.5 LBS (2.5 KG)
SHIPPING DIMENSIONS	15.0" X 5.0" X 11.5" (381 X 127 X 293 MM)
SHIPPING WEIGHT	8.0 LBS (3.7 KG)
HANDSET MATERIAL	HIGH IMPACT ABS
MICROPHONE	NOISE REDUCING ELECTRET
OPTIONAL MICROPHONE	NOISE CANCELING DYNAMIC
RECEIVER	HEARING AID COMPATIBLE
STANDARD MOUNTING	VERTICAL WALL
WIRING ACCESS	7/8" OPENING FOR OWNER SUPPLIED FITTING
HARDWARE MATERIAL	STAINLESS STEEL

Compliance	
INDUSTRY CANADA	1012 6721 A
FCC	HQHCAN-22517-TE-E
WEATHERPROOF	ENCLOSURE NEMA 3R
ENVIRONMENTAL SURVIVABILITY	MIL-STD-810E

Replacement Parts		
Part No.	Description	Field Replaceable
P000028	Microphone Cartridge – Noise Reducing	Yes
P000126	Housing	Yes
P001488	Door Spring	Yes
P001706	Hinge Pin – 8.390 Nylon	Yes
P002080	Receiver Cartridge	Yes
P002782	Ringer – Floyd Bell BR-3-39	Yes
P002988	Door C/W Velcro Latch	Yes
P002991	Fuse – Glass 0.25 Amp 250V	Yes
P002992	Surge Arrestor – TII 126L1	Yes
P002995	Hinge Pin Retaining Ring	Yes
P003045	Back plate	Yes
P004371	Handset Retainer – WRR-41 Only	Yes
P004538	Microphone Cartridge – Noise Canceling	Yes
P005391	Handset Assembly – C/W 4' Coil Cord For WRR-11	Yes
P005477	Handset Shell C/W 6' Coil Cord & Volume Control	Yes
P005479	Handset Shell – C/W 22" Armored Cord & Volume Control	Yes
P005582	Telephone Circuit Board	Yes
P005699	Handset Assembly – C/W 22" Armored Cord For WRR-41	Yes
P005778	Faceplate WRR (All Models)	Yes
P005917	Reed Switch	Yes
P005961	Handset Cradle – C/W Reed Switch	Yes

Government Certification

Attached to the telephone are labels for *Industry Canada* and the *United States Federal Communications Commission*. These identify equipment certifications indicating the 60 and 70 series telephones meet certain telecommunications network protective, operational and safety requirements. These agencies do not guarantee the equipment will operate to the user's satisfaction.

Before installing this telephone equipment, users should ensure it is permissible to connect the equipment to facilities of the local telecommunications company.

Equipment must be installed using acceptable connection methods. In some cases, the telephone users inside wiring, associated with a single line service, may be extended by a certified connector assembly (telephone extension cord). The customer should be aware that in some situations compliance with the above conditions may not prevent degradation of service.

Repairs to certified equipment should be made by a supplier designated authorized maintenance facility.

For their own protection users should ensure the electrical ground connections of the power utility, telephone lines and internal metallic water pipe systems, if present, are connected. This precaution may be particularly important in rural areas.

CAUTION: Users should not attempt to make ground connections, but should contact the appropriate electrical inspection authority or electrician.

Load Number (LN)

The Load Number (LN) assigned to each terminal device denotes the percentage of the total load to be connected to a telephone loop used by the device. Termination on a loop may consist of any combination of devices subject only to the requirement that the total of the Load Numbers of all the devices does not exceed 100.

Notification to Telephone Company

Upon request, the customer must notify the telephone company of the particular line to which the connection will be made and provide the Industry Canada or FCC registration number. The local telephone company may request disconnection of the telephone where alterations or malfunctions affect the telephone's performance.

United States Federal Communications Commission

This equipment generates, uses and can radiate radio frequency energy, and if not installed and used in accordance with the instruction manual, may cause interference to radio communications. It has been tested and found to comply with the limits for Class A computing device pursuant to Subpart J of Part 15 of FCC rules, which are designed to provide reasonable protection against such interference when operated in a commercial environment. Operation of this equipment in a residential area is likely to cause interference in which case the user, at his own expense, will be required to take whatever measures may be required to correct the interference.

Interference

There is no guarantee that interference will not occur in a particular installation. If interference to radio or television reception from this equipment is suspected, proceed as follows:

1. Unplug the set, check for the interference.
2. Re-orient the receiving antenna.
3. Relocate the set with respect to the receiver.
4. Move the set away from the receiver.

If necessary, consult the supplier or an experienced radio/television technician for additional suggestions.

FCC Rules and Ringer Equivalence Number

This equipment complies with Part 68 of the FCC Rules. On the side of this equipment is a label that contains, among other information, the FCC registration number and ringer equivalence number (REN) for this equipment. If requested, this information must be provided to the telephone company.

The REN is used to determine the quantity of devices, which may be connected to the telephone line. Excessive RENs on the telephone line may result in the devices not ringing in response to an incoming call. In most, but not all areas, the sum of the RENs should not exceed five. To be certain of the number of devices that may be connected to the line, as determined by the total RENs, contact the telephone company to determine the maximum REN for the calling area.

Service changes and Limitations

The telephone company may make changes in its facilities, equipment, operations, or procedures that could affect the operation of the equipment. If this happens, the telephone company will provide advance notice in order for you to make the necessary modifications in order to maintain uninterrupted service.

This equipment cannot be used on public coin telephone service as provided by your telephone company. Connection to party line service is subject to state tariffs (contact the state public utility commission, public service commission or corporate commission for information.)

Warranty

Guardian Telecom, a division of Circa Enterprises Inc. warrants that its products are free from defective workmanship and materials. Guardian Telecom will, within three years from the date of final sale to the customer, replace or repair any such products provided they are returned to our facilities for examination. Freight costs (including brokerage if applicable), both to and from Guardian, are the sole responsibility of the customer. This warranty does not extend to any items that are deemed to have been misused, modified, neglected, improperly specified, improperly installed, or used in violation of instructions or specifications approved by Guardian Telecom. Guardian Telecom, a division of Circa Enterprises Inc. shall not be liable for incidental or consequential damage of any kind caused by any defect in our product. The total liability shall not, under any circumstances, exceed the purchase price of the products furnished by Guardian Telecom, a division of Circa Enterprises Inc.

A return authorization must be obtained prior to warranty claims or repairs.

Disclaimer

The products covered by this manual are designed for use in Industrial Environments and/or Hazardous Locations. Due to the range of possible applications for these instruments, the manufacturer will not be responsible for damages or losses of any kind suffered as a result of the use of this product, including consequential damages.

Warning

This device may be opened and reassembled by qualified personnel only, for the purposes of installing the product, making adjustments and replacing components, following the instructions in the product manual.

High voltages may be present in this product when connected to telephone wiring.

Service Telephone Number

1-800-363-8010

Guardian Telecom provides a customer service telephone number that is toll-free within North America. If you need assistance when installing or operating this product, please call the toll-free telephone number between regular business hours (8:00AM-5:00PM), Mountain Standard Time. If you are calling outside of regular business hours, please leave a detailed message, and a member of Guardian Telecom's Service Department will return your call as soon as possible. If your product requires service, Guardian personnel will supply you with an RMA (return materials authorization) number over the telephone or through our web site product return page. This number must be included with your return address and the name of the person to contact.

Guardian Telecom, a division of Circa Enterprises Inc.

Toll-free 1-800-363-8010

Ph. (403) 258-3100

Fax. (403) 255-2595

www.guardiantelecom.com

Feedback

Guardian Telecom continually strives to make reliable, durable, and easy to use products. If you, as an installer or user of our equipment, have any suggestions for improvements to this or any of our products or documents, including this manual, we would appreciate hearing from you.

Guardian Product Return
Guardian products have been quality tested and are in full working order when shipped from the factory, given the rugged nature of these products shipping is not expected to damage a unit. In the unlikely event of a malfunction, Guardian follows the three-step procedure below.
<i>Step I - On-Site Correction</i>
<ul style="list-style-type: none"> • The most common source of difficulties with a new product is improper installation in one of two ways: incorrect wiring connections or connection to an incorrect power source.
<ul style="list-style-type: none"> • Product wiring needs to be properly connected to the on-site wiring. Correct wiring instructions are shown in the user manual included with the product.
<ul style="list-style-type: none"> • Connecting a telephone to a standard power source, rather than tip & ring, will blow the telephone's internal, user-replaceable fuse. In the event of fuse burnout, disconnect the telephone from the power source, replace the fuse, and reconnect following the wiring diagrams provided with the product.
<i>Step II - Return Materials Authorization (RMA)</i>
<ul style="list-style-type: none"> • When a product has been installed following user manual instructions, and the unit fails to operate, the user must contact Guardian Telecom to obtain authorization to return the product. This can be done by completing an RMA form online at https://www.guardiantelecom.com/support/rma/, or by calling the service telephone number given in this manual.
<ul style="list-style-type: none"> • After providing information on the product, the owner and the nature of the problem, Guardian will issue a RMA number, to be shown on documentation returned with the product.
<ul style="list-style-type: none"> • In addition to the RMA number, shipping documents should include name, address and telephone number of the owner along with contact information for the person responsible for the repair and/or the user who identified the malfunction.
<ul style="list-style-type: none"> • (Where a product is being returned for repair from outside of Canada, customs documentation must show the product's serial number, date of export [date of purchase], and a notation that the equipment is: "Canadian goods returning.")
<i>Step III - Factory Authorized Service</i>
<ul style="list-style-type: none"> • Once received, each product is carefully inspected and tested. If the product is under warranty, repairs are completed and the product returned to the owner, generally within five working days of receipt by the factory.
<ul style="list-style-type: none"> • A product that has been subjected to misuse, neglect or accident or is beyond the warranty period will be evaluated. The service department will provide the owner's representative with a repair cost estimate. Once approved, repairs are completed and the product returned, generally within five working days.

Cleaning Tips for Guardian Telephones

Guardian Telephones may occasionally need to be cleaned to maintain appearance. Generally, wiping the surface with a clean, water-dampened cloth will remove most films or residues. If the soiling is too stubborn for plain water, a mild detergent solution may be used. Be sure to wipe away any detergent residue with a plain water dampened cloth. The Telephone may be cleaned with any general-purpose household glass and surface type cleaner. Do not spray the telephone directly! Spray the cleaner on a soft cloth then wipe the surface. Pre-treated cloths, such as those used for eyeglasses or cameras, may be used to clean the Telephone. Premoistened towelettes may also be used, however, avoid those containing lanolin or aloe, as they will leave a slippery residue. The handset and surface of the telephone may be cleaned with disinfectants used for general cleaning in a medical environment. Isopropyl alcohol may be used applied with a cloth. Avoid using alcohol on silicon-based keypads, since doing so may significantly degrade legibility.

- Do not use furniture polishes, waxes or plasticizer-based cleaner (Armor All etc.)
- Do not use lanolin, aloe, glycerin or other skin care type products.
- Do not apply any solvent such as acetone, mineral spirits etc.
- Do not directly spray or immerse the handset.

Storage

General Storage (All situations):

- Note any stacking limits or warnings on packaging (if any).
- Do not store in temperatures over +80C.
- Store in original packaging if possible until needed.

Long Term Storage (> 6 Months):

- If area is air-conditioned and not subject to high changes in humidity, continue to store in original packaging.
- If wide humidity shifts are expected, then use these steps:
 - Remove product from packaging (including plastic bags) and store on shelf in open air.
 - If area is subject to a high degree of dust, to help maintain cosmetic appearance you can cover with cloth (Do not cover with plastic or materials that will trap moisture) or clean periodically.
 - Do not store out of packaging long term where they are exposed to sunlight. Long-term exposure to UV may cause fading on plastic parts.



SAI GLOBAL
ISO 9001:2015

Guardian Telecom, a division of Circa Enterprises Inc.
Toll-free 1-800-363-8010
Phone (403) 258-3100
Fax. (403) 255-2595
www.guardiantelecom.com
E-mail: sales@guardiantelecom.com
(Click to open message box)

Tough. Trusted. True.

© Circa Enterprises 2020