

HDE-V SERIES

Heavy Duty Emergency Telephones

HDE-V SERIES HEAVY DUTY VOIP EMERGENCY & PUBLIC ACCESS TELEPHONES

- HDE-11-V – Recessed/Single Emergency/ 0.5 Watt
- HDE-1100-V – Recessed/Single Call Button & 12 Digit Keypad/ 0.5 Watt
- HDE-12-V – Wall Mount/Single Emergency/0.5 Watt
- HDE-1200-V – Wall Mount/Single Call Button & 12 Digit Keypad/0.5 Watt

FEATURES and BENEFITS

- Supports CISCO SRST (User selectable).
- Supports Mitel Resiliency (User Selectable).
- Adaptive full-duplex voice operation
- PoE 802.3af enabled (Power-over-Ethernet) or alternate power source
- Compatible with SIP RFC 3261 compliant IP-PBX and Cloud based servers
- Auxilliary Relay to control external devices with multiple control modes (Refer to document P007402 – VoIP Setup and Configuration Guide)
- Network web management interface
- Guardian Discovery Utility makes it easy to detect, locate and launch the web based configuration screens
- Web Interface provides full configuration over device. Some key features include

- Microphone default level settings
- LED activation control, (User selectable), (2 - LEDs)
- Relay activation management.
- Call timers
- Event Management – Real Time Monitoring.
- Product Updates.
- Product Automated configuration

- HDE-V models with an "Emergency" push button – depressing the button once automatically rings a designated number to summon help
- HDE-V models with a "Push To Call" button – depress the button once and it allows the user to dial out or it will dial a pre-programmed number. A call may be initiated from the phone or from the monitoring station
- Control Relay – network configurable auxiliary relay standard on all models
- Night ringer mode – refer to product manual
- Powder coated, corrosion resistant enclosures
- LED – There are up to 2 LED indicators which can be set to activate on specific operations status or remote controlled
- ADA (American Disability Act) compliant label
- Speaker – hands free operation
- Operating temp: -40° to +140°F (-40° to +60°C)
- Adaptive Echo Cancelling – Self learning echo reduction system



HDE-11-V



HDE-1100-V



HDE-12-V



HDE-1200-V

HD RANGE OF TELEPHONES

Guardian's HD RANGE Heavy Duty Emergency Industrial Telephones are intended for use in public areas where direct assistance or hands-free communication is required.

HDE-V SERIES OF TELEPHONES

Guardian's HDE-V SERIES telephones provide a two-way link to emergency, access or information assistance through full-duplex phone transmission. A call may be initiated from the phone by pushing the button which routes the call to its assigned extension. These phones also provide the capability of monitoring the status of each unit from a remote location, informing personnel of a malfunction.

HDE-V Telephones are compatible with most SIP-based IP-PBX servers that comply with SIP RFC 3261. See our Interoperability Guide for details.

APPLICATIONS

HDE-V Telephones are designed to provide reliable communications in environments subject to vandalism, moisture, dust and corrosive chemicals such as:

Universities
Elevators
Parking Facilities
ATMs
Transit Authorities
Medical Centers
Industrial Parks

Public Access Areas
Building Entrances
Plant Entry Gates
Sporting Facilities
Amusement Parks
Senior Citizen Housing
and more ...



GUARDIAN
T E L E C O M

tough. trusted. true.



SAI GLOBAL
ISO 9001:2015

OVERALL DIMENSIONS

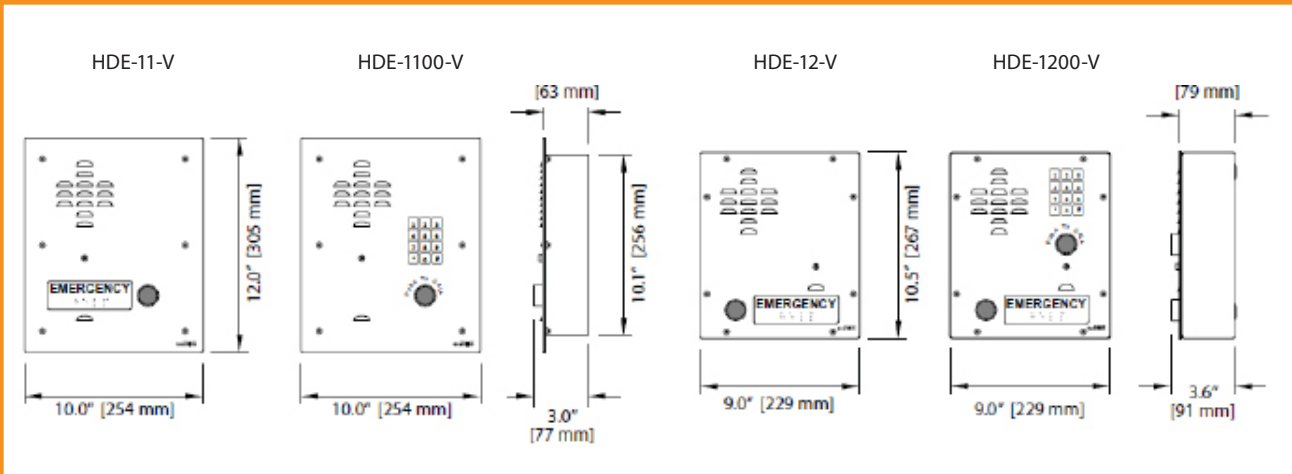

HDE-V Series Heavy Duty Emergency & Public Access IP Telephones

ENGINEERING SPECIFICATIONS

ELECTRICAL PERFORMANCE

Ethernet Network Rate	10/100 Mbps
Maximum Speaker Volume	1 Watt Peak
Protocol	SIP (RFC 3261 Compliant)

ELECTRICAL REQUIREMENTS

Power Requirements	
METHOD 1 - Thru LAN: POE 802.3 af (44-57V)	Switch OR via POE Injector
METHOD 2 - External PS:	24VDC @ 1A
Auxiliary Relay	1.0A @ 30V

ENVIRONMENTAL

Storage Temp:	-58° to +176°F (-50° to +80°C)
---------------	--------------------------------

MECHANICAL SPECIFICATIONS

Body Construction	16 Ga Mild Steel
Finish	Zinc Dichromate Plated & Powder Coated
Net Weight	
HDE-11-V	6.4 lbs (2.9 kg)
HDE-1100-V	6.8 lbs (3.1 kg)
HDE-12-V	7.0 lbs (3.2 kg)
HDE-1200-V	7.2 lbs (3.3 kg)
Shipping Weight	10.0 lbs (4.6 kg)
Shipping Dimensions (L x W x D)	16.0" x 10.5" x 9.5" (407 x 267 x 242 mm)
Mounting	Vertical Wall or Recessed
Wiring Access	
HDE-11-V & HDE-1100-V	- Two 7/8" Holes For Owner Supplied Fittings
HDE-12-V & HDE-1200-V	- One 7/8" Hole For Owner Supplied Fittings
Hardware Material	Stainless Steel

COMPLIANCE

FCC	Part 15 [†] , Class A
IC	ICES-003 CLASS A
	CISPR 22: 2008
IEC	61000-6-2: 2005

[†] This device complies with Part 15 of the FCC Rules. Operation is subject to the following two conditions: (1) This device may not cause harmful interference, and (2) this device must accept any interference received, including interference that may cause undesired operation.

SUPPORTED PROTOCOLS

SIP
HTTP Web base configuration
DHCP Client
TFTP Client
RTP
RTP/AVP Audio Video Profile
Facilities auto provisioning configuration values on boot
Audio Encoding
G711.1
722.1 (SIREN7)
G722.2 (AMR-AB)
G729.1 (729J & 729EV)

ORDERING INFORMATION

Warranty: Three years parts and labor

Order No.	Description
P6995	HDE-11-V Recessed/Single Emergency Call Button/Auxiliary Relay
P6996	HDE-1100-V Recessed/Single Push To Call Button & 12 Digit Metal Keypad/Auxiliary Relay
P6997	HDE-12-V Wall Mount/Single Emergency Call Button/Auxiliary Relay
P6998	HDE-1200-V Wall Mount/Emergency Call Button/Push To Call Button & 12 Digit Metal Keypad/Auxiliary Relay

Options

CC	Conformal Coated Circuit Board
MS	Mushroom Switch for HDE-11-V, HDE-12-V & HDE-1200-V
BS	Blue Switch for HDE-V

Distributed by:



GUARDIAN TELECOM, a division of CIRCA ENTERPRISES INC.
 Calgary, Alberta, Canada
 Telephone: 403 258-3100 Facsimile: 403 253-4967
 1-800-363-8010 (North America)
 info@guardiantelecom.com | www.guardiantelecom.com