



Heavy Duty Ringdown/Autodialer Telephone Panel Insert

MFR Series

(Replaces Insert in Northern Telecom and Guardian Telecom Enclosures)

Installation & Operation

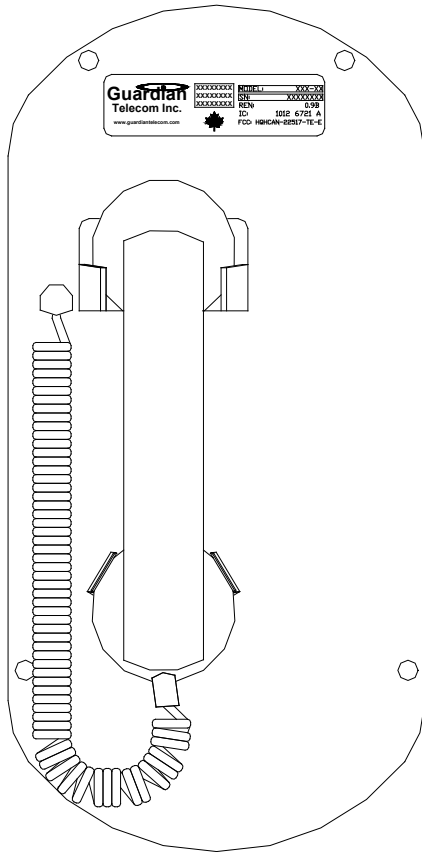

Model MFR - 11 (P5428)

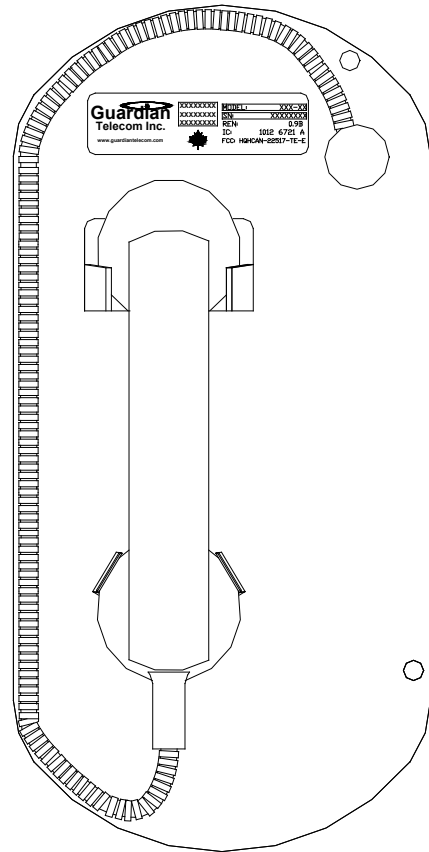

Model MFR - 41 (P5429)

Table of Contents

Package Contents.....	2
Models and Options	2
Accessories.....	2
Overview	3
Features.....	3
Installing the MFR Telephone Insert.....	5
Field Repairs.....	5
Specifications.....	6
Replacement Parts.....	7
Storage	7
Government Certification.....	8
Warranty	9
Disclaimer	9
Warning	9
Service Telephone Number.....	9
Feedback	9
Guardian Product Return	10

Table of Figures

Figure 1 - MFR Features.....	4
Figure 2 - MFR Electrical Connections.....	4

Package Contents

- One (1) MFR Telephone
- One (1) Installation and Operation manual

Models and Options

P5428 Model MFR-11 Ringdown Telephone Panel Insert for locking or non-locking door enclosure without internal ribs on right side, volume control handset and Coil cord.

P5431 Model MFR-11 Ringdown Telephone Panel Insert for earlier Northern Telecom, locking door enclosure with internal ribs on right side. Volume control handset and Coil cord.

P5429 Model MFR-41 Ringdown Telephone Panel Insert for locking or non-locking door enclosure without internal ribs on right side. Volume control handset and armored cord.

Accessories

- P7225** Weatherproof ring detect relay
- P7229** Weatherproof off-hook detect relay

Overview

MFR Heavy Duty Ringdown Telephone Insert

The MFR Ringdown Telephone Insert replaces the insert in Northern Telecom or Guardian Telecom weatherproof telephones. The insert uses up-to-date circuitry, is simple to install and requires no changes to the original enclosure or the wiring leading to the enclosure. This upgrade is economical and ensures many additional years of trouble free service, provided that the original enclosure is in good condition.

The MFR telephone may be supplied with an optional Auto Dialer or dialing may be configured by the PABX. If an Auto Dialer is ordered with the MFR refer to the manual for the Auto Dialer for instructions on programming and for compliances

Features

Enclosure

- utilizes the original Northern Telecom or Guardian Telecom weatherproof enclosure

Encapsulated Circuitry

- circuit boards are resistant to corrosive agents (e.g. H₂S, SO₂ and NH₃) and environments with high humidity

Magnetic Reed Hook Switch

- no moving parts

Fuse

- prevents damage to the electronic circuits in the event of a lightning strike or a high voltage spike on the telephone line

Noise Reducing Microphone

- allows a high level of intelligibility in locations with high background noise

Heavy Duty Handset Cord

- withstands excessive use (armored cord on MFR-41)

Hearing-Aid Compatible

- compatible with inductively coupled hearing-aid devices

Receiver Volume Control

- Switch in handset provides 13.5dB of range

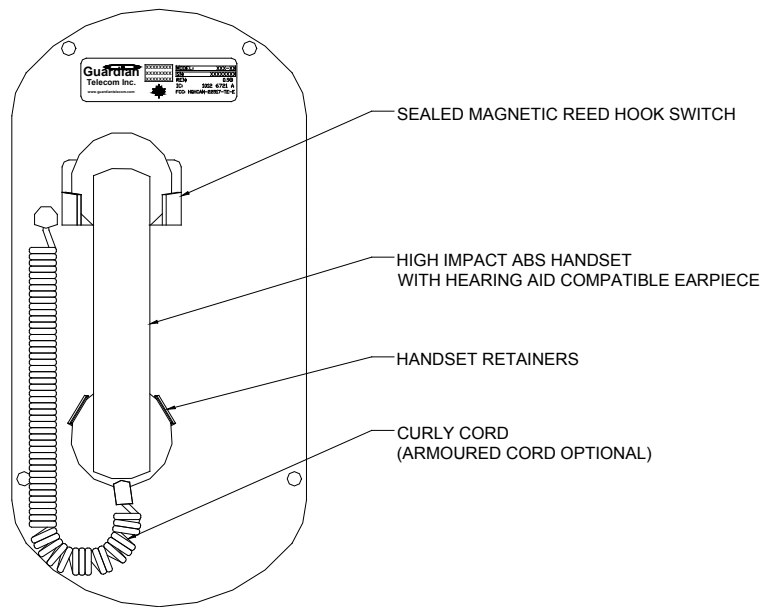

Figure 1 - MFR Features

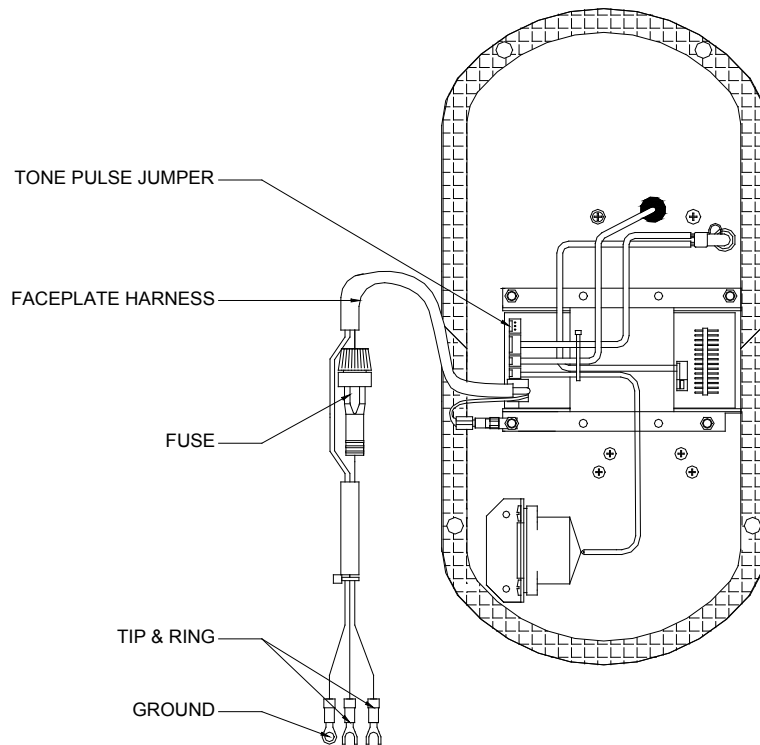

Figure 2 - MFR Electrical Connections

Installing the MFR Telephone Insert

- Follow all appropriate electrical codes and use only approved electrical fittings for the installation.
- Ensure that none of the electrical connection circuits are live.
- Remove the old faceplate from the telephone and retain the four mounting screws.
- For telephones equipped with a surge arrestor, attach the blue and orange wires to the two outside terminals of the surge arrestor. Attach the green wire to the center terminal on the surge arrestor.
- For telephones without a surge arrestor, cut off the terminal lugs on the orange and blue wires and connect them to the tip and ring lines using either crimp connectors or wire nuts. Attach the green wire to a ground screw in the housing.
- Insert the new faceplate into the housing and secure using the four mounting screws previously removed.
- Test the unit by calling to and from another unit on the exchange.

See: Government Certification.

See: Figure 2 - MFR Electrical Connections

Field Repairs

Field repairs may only be carried out by qualified technicians using OEM parts. Substitution of parts voids warranty and may pose a hazard to users of the equipment.

- Disconnect the telephone from Tip and Ring power supplied by the PABX or central office before attempting repairs.
- Carefully remove the faceplate assembly and separate from the housing by disconnecting the harness plugs. NOTE that the handset and all electronics are attached to the front plate.
- Perform the necessary repairs or adjustments.
- Carefully replace the front plate and install all four screws. Do not over tighten the cover screws; there is a flexible gasket between the cover and the body. Excessive tightening of the screws deforms the gasket and reduces the weather resistance of the set.

Fuse Replacement

- Remove the old fuse by pushing in the end cap of the fuse holder and turning counterclockwise to open. Insert a new 0.25 amp, 250Volt, 3AG fast blow fuse and close the fuse holder.
- If, on reconnecting power, the fuse fails, check the telephone system wiring. The fuse protects the Tip and Ring line from the telephone system. It is usually powered at 48 volts DC and must not be connected to 120 volts AC.

See: Figure 2 - MFR Electrical Connections & Replacement Parts

Specifications	
<i>ELECTRICAL PERFORMANCE</i>	
AUDIBLE FREQUENCY RANGE	300 – 3400 Hz
TRANSMIT OBJECTIVE LOUDNESS RATING (TOLR)	-38 +/- 3 dB
RECEIVER VOLUME ADJUSTMENT	13.5 dB IN 2.7 dB STEPS, 3 STEPS UP AND 2 STEPS DOWN
RECEIVE OBJECTIVE LOUDNESS RATING (ROLR)	
-AT NOMINAL VOLUME LEVEL	50.0 +/- 3 dB
-AT MAXIMUM VOLUME LEVEL	42.0 +/- 3 dB
-AT MINIMUM VOLUME LEVEL	55.5 +/- 3 dB
SIDE TONE OBJECTIVE RATING (SOLR)	
-AT NOMINAL VOLUME LEVEL	11 +/- 4 dB
-AT MAXIMUM VOLUME LEVEL	7 +/- 4 dB
-AT MINIMUM VOLUME LEVEL	14 +/- 4 dB
RINGER OUTPUT	65 dB MAX.
FCC RINGER EQUIVALENC (REN)	0.8 B
SET IMPEDANCE	600 OHMS NOMINAL
MAXIMUM LOOP	15,000 FEET OF 22 AWG COPPER
<i>ELECTRICAL REQUIREMENTS</i>	
RINGER SENSITIVITY	40 – 100 V, 16 – 25 Hz
LINE VOLTAGE	24 –56 VDC
LOOP CURRENT	20 – 120 mA
CONNECTION METHOD	SURGE ARRESTOR OR SPLICE
MICROPHONE	NOISE REDUCING ELECTRET
<i>ENVIRONMENTAL</i>	
TEMPERATURE	-40° TO +60° C (-40° TO +140° F)
<i>MECHANICAL</i>	
HOOK SWITCH (CRADLE SWITCH) LIFE	>1,000,000 OPERATIONS
FACEPLATE	STEEL – ZINC DICHROMATE PLATED AND POWDER COATED
NET WEIGHT	4 LBS./1.8 KG
DIMENSIONS (H X W)	13.8" X 6.8" (350 MM X 173 MM)
SHIPPING WEIGHT	4.5 LBS./2 KG
SHIPPING DIMENSIONS	15.0" X 5.0" X 11.5" (381 X 127 X 293 MM)
HANDSET CORD	ALCRYN COLD TEMPERATURE (ARMORED OPTIONAL)
HANDSET MATERIAL	HIGH IMPACT ABS
HARDWARE MATERIAL	STAINLESS STEEL

Compliance	
INDUSTRY CANADA	1012 6721 A
FCC	HQHCAN-22517-TE-E

Replacement Parts	
Part No.	Description
P006396	MFR-11 Faceplate Assembly C/W Coil Cord Volume Control Handset
P006397	MFR-41 Faceplate Assembly C/W Armored Cord Volume Control Handset
P002786	Handset Cradle
P004371	Handset Retainer
P005391	Handset Assembly C/W 4' Coil Cord and Volume Control Handset
P005699	Handset Assembly C/W 22" Armored Cord and Volume Control Handset
P005582	Telephone Circuit Board Assembly
P002782	Ringer - Floyd Bell BR-3-39
P005917	Reed Switch
P002992	Surge Arrestor – TII 126L1
P002991	Fuse - Glass 0.25 Amp 250V

Storage

General Storage (All situations):

- Note any stacking limits or warnings on packaging (if any).
- Do not store in temperatures over +80C.
- Store in original packaging if possible until needed.

Long Term Storage (> 6 Months):

- If area is air conditioned and not subject to high changes in humidity, continue to store in original packaging.
- If wide humidity shifts are expected, then use these steps:
 - Remove product from packaging (including plastic bags) and store on shelf in open air.
 - If area is subject to a high degree of dust, to help maintain cosmetic appearance you can cover with cloth (Do not cover with plastic or materials that will trap moisture) or clean periodically.
 - Do not store out of packaging long term where they are exposed to sunlight. Long term exposure to UV may cause fading on plastic parts.

Government Certification

Attached to the telephone are labels for *Industry Canada* and the *United States Federal Communications Commission*. These identify equipment certifications indicating the 60 and 70 series telephones meet certain telecommunications network protective, operational and safety requirements. These agencies do not guarantee the equipment will operate to the user's satisfaction.

Before installing this telephone equipment, users should ensure it is permissible to connect the equipment to facilities of the local telecommunications company.

Equipment must be installed using acceptable connection methods. In some cases, the telephone users inside wiring, associated with a single line service, may be extended by a certified connector assembly (telephone extension cord). The customer should be aware that in some situations compliance with the above conditions may not prevent degradation of service.

Repairs to certified equipment should be made by a supplier designated authorized maintenance facility.

For their own protection users should ensure the electrical ground connections of the power utility, telephone lines and internal metallic water pipe systems, if present, are connected. This precaution may be particularly important in rural areas.

CAUTION: Users should not attempt to make ground connections, but should contact the appropriate electrical inspection authority or electrician.

Load Number (LN)

The Load Number (LN) assigned to each terminal device denotes the percentage of the total load to be connected to a telephone loop used by the device. Termination on a loop may consist of any combination of devices subject only to the requirement that the total of the Load Numbers of all the devices does not exceed 100.

Notification to Telephone Company

Upon request, the customer must notify the telephone company of the particular line to which the connection will be made and provide the Industry Canada or FCC registration number. The local telephone company may request disconnection of the telephone where alterations or malfunctions affect the telephone's performance.

United States Federal Communications Commission

This equipment generates, uses and can radiate radio frequency energy, and if not installed and used in accordance with the instruction manual, may cause interference to radio communications. It has been tested and found to comply with the limits for Class A computing device pursuant to Subpart J of Part 15 of FCC rules, which are designed to provide reasonable protection against such interference when operated in a commercial environment. Operation of this equipment in a residential area is likely to cause interference in which case the user, at his own expense, will be required to take whatever measures may be required to correct the interference.

Interference

There is no guarantee that interference will not occur in a particular installation. If interference to radio or television reception from this equipment is suspected, proceed as follows:

1. Unplug the set, check for the interference.
2. Re-orient the receiving antenna.
3. Relocate the set with respect to the receiver.
4. Move the set away from the receiver.

If necessary, consult the supplier or an experienced radio/television technician for additional suggestions.

FCC Rules and Ringer Equivalence Number

This equipment complies with Part 68 of the FCC Rules. On the side of this equipment is a label that contains, among other information, the FCC registration number and ringer equivalence number (REN) for this equipment. If requested, this information must be provided to the telephone company.

The REN is used to determine the quantity of devices which may be connected to the telephone line. Excessive RENs on the telephone line may result in the devices not ringing in response to an incoming call. In most, but not all areas, the sum of the RENs should not exceed five. To be certain of the number of devices that may be connected to the line, as determined by the total RENs, contact the telephone company to determine the maximum REN for the calling area.

Service changes and Limitations

The telephone company may make changes in its facilities, equipment, operations, or procedures that could affect the operation of the equipment. If this happens, the telephone company will provide advance notice in order for you to make the necessary modifications in order to maintain uninterrupted service.

This equipment cannot be used on public coin telephone service as provided by your telephone company. Connection to party line service is subject to state tariffs (contact the state public utility commission, public service commission or corporate commission for information.)

Warranty

Guardian Telecom warrants your product to be free of defects in material and workmanship for a period of one year. Guardian Telecom will repair or replace any defective unit that is under warranty free of charge.

This warranty is null and void if any non-authorized modifications have been made to this product, or if it has been subjected to misuse, neglect, or accident. This warranty covers bench repairs only; such repairs must be made at Guardian Telecom or an authorized service depot. Guardian Telecom is not responsible for costs incurred for on-site service calls, freight, or brokerage.

A return authorization must be obtained prior to warranty claims or repairs.

Disclaimer

The products covered by this manual are designed for use in Industrial Environments and/or Hazardous Locations. Due to the range of possible applications for these instruments the manufacturer will not be responsible for damages or losses of any kind suffered as a result of the use of this product, including consequential damages.

Warning

This device may be opened and reassembled by qualified personnel only, for the purposes of installing the product, making adjustments and replacing components, following the instructions in the product manual.

High voltages may be present in this product when connected to telephone wiring.

Service Telephone Number

1-800-363-8010

Guardian Telecom provides a customer service telephone number which is toll-free within North America. If you need assistance when installing or operating this product, please call the toll-free telephone number between regular business hours (8:00AM-5:00PM), Mountain Standard Time. If you are calling outside of regular business hours, please leave a detailed message, and a member of Guardian Telecom's Service Department will return your call as soon as possible. If your product requires service, Guardian personnel will supply you with an RMA (return materials authorization) number over the telephone or through our web site product return page. This number must be included with your return address and the name of the person to contact.

Guardian Telecom, a division of Circa Enterprises Inc.

Toll-free 1-800-363-8010

Ph. (403) 258-3100

Fax. (403) 253-4967

www.guardiantelecom.com

Feedback

Guardian Telecom continually strives to make reliable, durable, and easy to use products. If you, as an installer or user of our equipment, have any suggestions for improvements to this or any of our products or documents, including this manual, we would appreciate hearing from you.

Guardian Product Return
Guardian products have been quality tested and are in full working order when shipped from the factory, given the rugged nature of these products shipping is not expected to damage a unit. In the unlikely event of a malfunction Guardian follows the three step procedure below.
<i>Step I - On-Site Correction</i>
<ul style="list-style-type: none"> • The most common source of difficulties with a new product is improper installation in one of two ways: incorrect wiring connections or connection to an incorrect power source.
<ul style="list-style-type: none"> • Product wiring needs to be properly connected to the on-site wiring. Correct wiring instructions are shown in the user manual included with the product.
<ul style="list-style-type: none"> • Connecting a telephone to a standard power source, rather than tip & ring, will blow the telephone's internal, user-replaceable fuse. In the event of fuse burn-out, disconnect the telephone from the power source, replace the fuse, and reconnect following the wiring diagrams provided with the product.
<i>Step II - Return Materials Authorization (RMA)</i>
<ul style="list-style-type: none"> • When a product has been installed following user manual instructions, and the unit fails to operate, the user must contact Guardian Telecom to obtain authorization to return the product. This can be done by completing a RMA form online at www.guardiantelecom.com, or by calling the service telephone number given in this manual.
<ul style="list-style-type: none"> • After providing information on the product, the owner and the nature of the problem, Guardian will issue a RMA number, to be shown on documentation returned with the product.
<ul style="list-style-type: none"> • In addition to the RMA number, shipping documents should include name, address and telephone number of the owner along with contact information for the person responsible for the repair and/or the user who identified the malfunction.
<ul style="list-style-type: none"> • (Where a product is being returned for repair from outside of Canada, customs documentation must show the product's serial number, date of export [date of purchase], and a notation that the equipment is: "Canadian goods returning.")
<i>Step III - Factory Authorized Service</i>
<ul style="list-style-type: none"> • Once received, each product is carefully inspected and tested. If the product is under warranty, repairs are completed and the product returned to the owner, generally within five working days of receipt by the factory.
<ul style="list-style-type: none"> • A product that has been subjected to misuse, neglect or accident or is beyond the warranty period will be evaluated. The service department will provide the owner's representative with a repair cost estimate. Once approved, repairs are completed and the product returned, generally within five working days.



Guardian Telecom, a division of Circa Enterprises Inc.

Toll-free 1-800-363-8010

Phone (403) 258-3100

Fax. (403) 253-4967

www.guardiantelecom.com

E-mail: <mailto:sales@guardiantelecom.com>

(Click to open message box)

Tough. Trusted. True.

© Guardian Telecom 2018