

Page/Talk Switch Plate

Installation

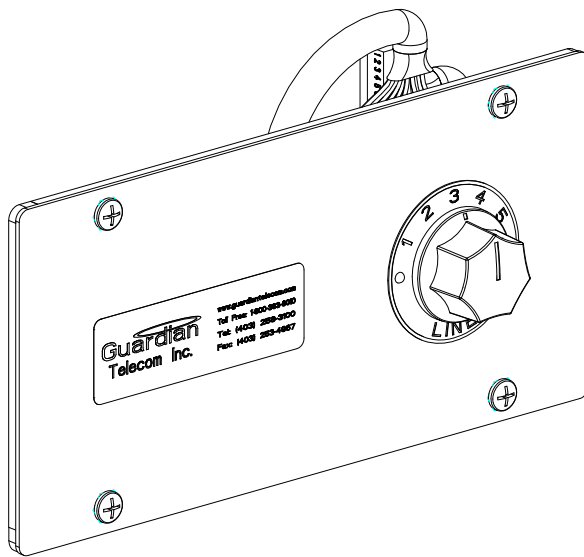

P5530

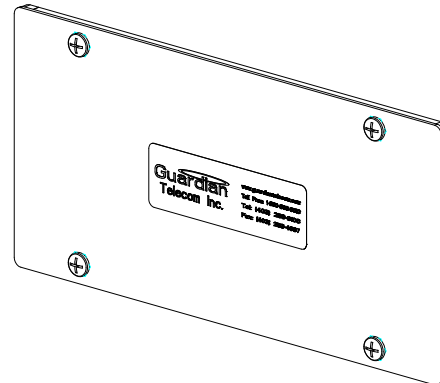

P5531

APPROVED FOR USE IN HAZARDOUS AREAS WHEN INSTALLED IN CONFORMANCE WITH CSA CERTIFICATE OF COMPLIANCE 1289924 (LR65547). SEE MANUAL NUMBER P006257 FOR DETAILS.

IF YOU HAVE QUESTIONS CONCERNING THIS PRODUCT PLEASE CONTACT OUR SERVICE DEPARTMENT BY PHONE, TOLL FREE IN NORTH AMERICA 1-800-363-8010, AT 1-403-258-3100 OUTSIDE OF NORTH AMERICA OR BY E-MAIL AT THE ADDRESS SHOWN BELOW.

WARNING

- High voltages may be present in this product when it is connected to system wiring.
- It is the responsibility of the end user to ensure that this product meets the requirements for the area in which it is to be installed and that it is installed and wired according to local regulations.

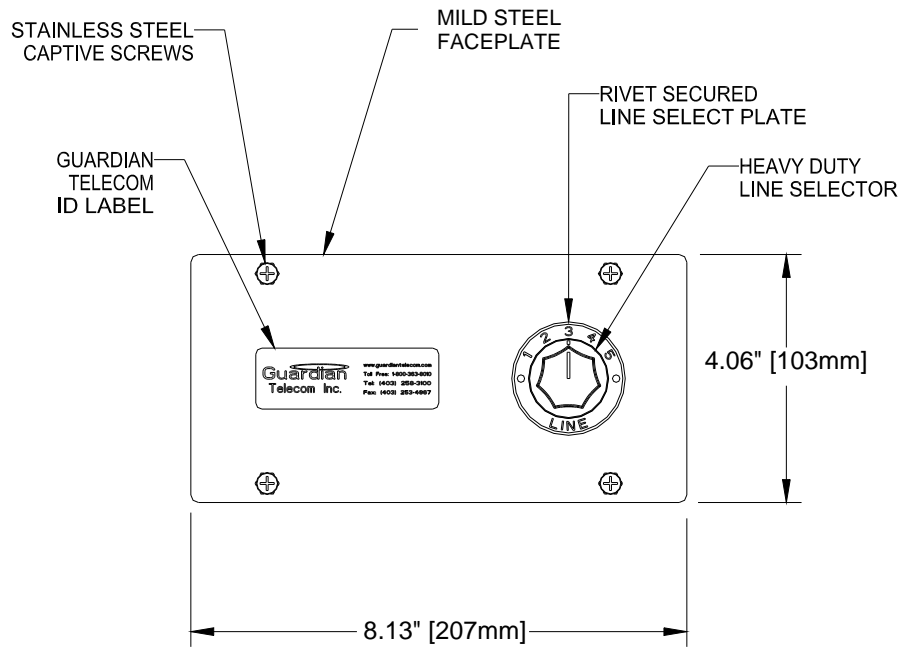

Features and Dimensions

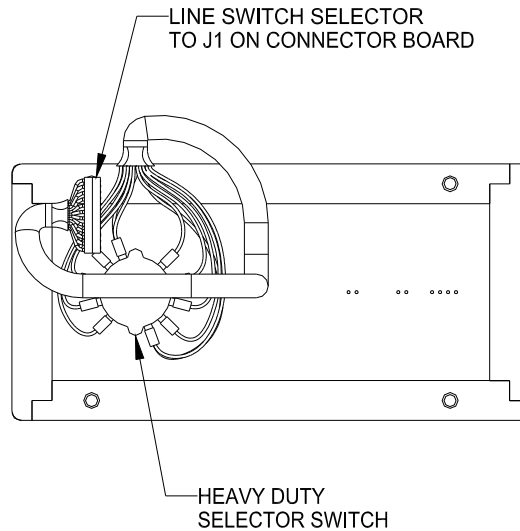

Electrical Connections

Replacement Parts

| Part No. | Description |
|-----------------|------------------------------------|
| P004738 | Switch - Five Channel With Harness |
| P004833 | Knob - Rotary Cap Pointer |
| P005923 | Plate - Five Line |
| P005924 | Plate - Single Line |