

# Explosion Proof Telephone

## Model EXT-401

### Installation & Operation



P002640 Rev. G 150109 1/9/2015 9:57 AM

### Table of Contents

Package Contents .....2

Overview .....3

Features.....3

Warnings.....5

General Requirements .....5

EXT 401 Models.....6

Options.....6

Installing the EXT-401 .....6

Wiring For Tip & Ring .....8

Wiring For Peripheral Signaling Device .....9

Wiring of Tip & Ring with Optional Disconnect Switch .....11

Installation of Peripheral Signaling Device with Power Disconnect Switch....12

Fuse Replacement .....13

Replacement of Telephone Handset Assembly .....14

Replacement of ISH1125 Headset .....15

Operating Instructions .....16

Engineering Specifications .....17

Replacement Parts.....18

Warranty.....20

Disclaimer .....20

Warning.....20

Service Telephone Number .....20

Feedback .....20

Guardian Product Return.....21

APPENDIX A - Hazardous Location Classification .....22

APPENDIX B - Applications.....23

### Table of Figures

Figure 1 - Features .....4

Figure 2 - Dimensions .....4

Figure 3 - Typical Installation.....7

Figure 4 - Lower Junction Box Wiring .....8

Figure 5 - Upper Junction Box Wiring .....9

Figure 6 - Typical Installation With Disconnect Switches .....10

Figure 7 - Optional Telephone Line Disconnect Switch Wiring.....11

Figure 8 - Power Disconnect Switch Wiring .....12

Figure 9 - Fuse Replacement .....13

Figure 10 - Handset Replacement .....14

Figure 11 - Headset Replacement .....15

Figure 12 - Headset Hook Switch Operation.....16

Figure 13 - I.D. and Compliance .....18

### Package Contents

- (1) EXT-401 Telephone
- (1) Installation & Operation Manual

## Overview

### ***Model EXT-401 Explosion Proof Telephone***

This explosion proof telephone provides safe and reliable communication in hazardous locations, up to and including Class I Division 1, (see Figure 13 - I.D. and Compliance). Only standard wiring and fittings are required to connect the telephone to the system; no barrier is necessary. Since the heavy duty cast aluminum enclosure is basically soundproof, an external device to signal incoming calls is required. The signaling device may be actuated by an optional internal or external ring detect relay.

## Features

### ***Enclosure***

- Cast copper free aluminum with powder coat finish.

### ***Internal Sealed Cavities***

- Completely seal the unit.

### ***Keypad***

- Standard configuration with an additional row of buttons for Last Number Redial, Link/Flash to access PABX features and Line Release to duplicate hanging up the handset (Link and Redial buttons may be replaced by Volume Up and Volume Down).
- One inch diameter buttons for gloves-on operation.

### ***Circuitry Coating***

- Circuit boards have a UV cured epoxy coating which provides protection from corrosive agents such as H<sub>2</sub>S, SO<sub>2</sub>, and NH<sub>3</sub>, and environments with high humidity.

### ***Magnetic Reed Hook Switch***

- No moving parts, activates when the handset is removed from or placed in the telephone cradle.

### ***Tone (DTMF)/Pulse Operation***

- Factory set to operate to tone (DTMF) exchanges unless pulse specified.

### ***Intrinsically Safe Handset Operation***

- The output from the telephone to the handset passes through an intrinsically safe barrier ensuring a high degree of safety.

### ***Field Replaceable Handset and Headset***

- The handset cord is attached to the telephone by a connector for ease of replacement.
- The cord is designed for industrial applications and is available in 10' (3m), 20' (6m) coiled and 22" armored lengths. An optional headset is available.

### ***Field Replaceable Fuse***

- A fitting in the bottom of the enclosure provides access to the fuse.

### ***Hearing-Aid Compatibility***

- The handset is compatible with inductively coupled hearing-aid devices.

### ***Receiver Volume Control***

- Selected models provide 13.5dB of range.

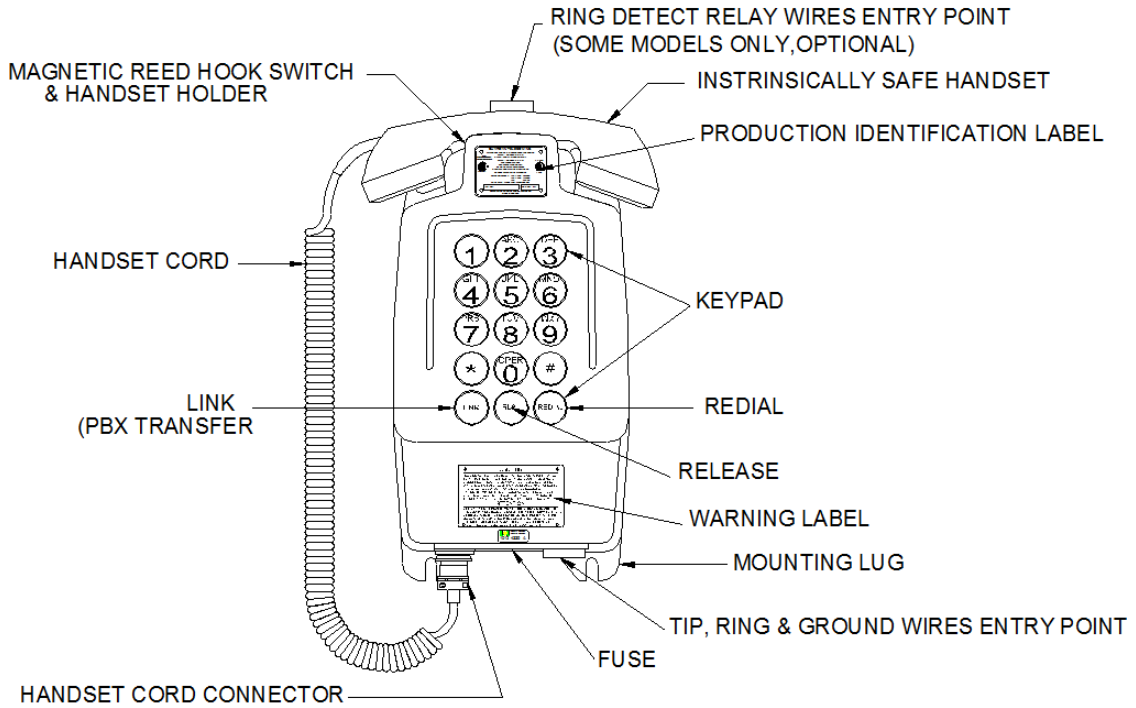

Figure 1 - Features

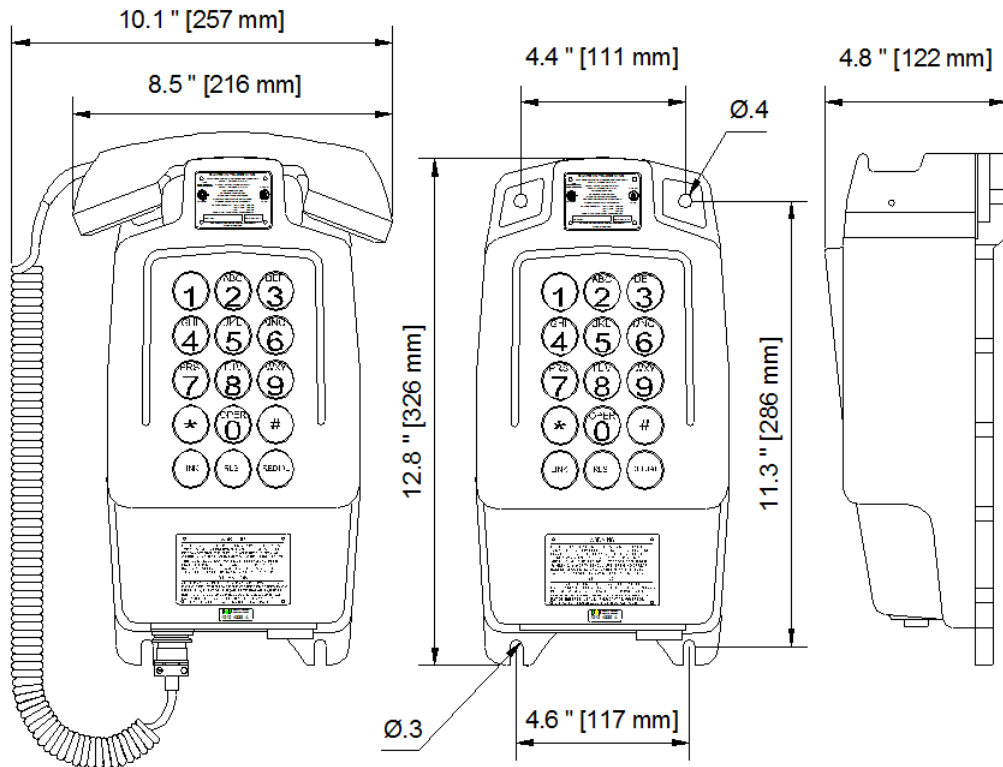

Figure 2 - Dimensions

### Warnings

- In no case should this telephone apparatus or wiring be installed in a location where acetylene may be present in the atmosphere.
- Two back cover retaining bolts on the model EXT-401 are factory sealed. Damage to the seals voids the warranty and safety approvals, and may compromise unit safety.
- It is the responsibility of the installer to advise a supervisor if any telephone equipment or wiring in a hazardous location may not comply with regulations and standards applicable to that location.
- Avoid creating a spark by striking tools or metal objects together, against concrete, stone, or any similar substance.
- Test equipment capable of producing an electric spark must not be used in an explosive atmosphere.
- All apparatus should be completely assembled and properly sealed before reconnecting power.

### General Requirements

- An EXT-401 telephone should only be installed with proper authorization. It is necessary for the customer and the telephone company to have a definite agreement regarding the location of the telephone unit, auxiliary apparatus, and protector (i.e. lightning arrestor at the demarcation block).

**NOTE:**

- To maintain maximum protection, broken or worn parts must be replaced immediately. Any abnormal conditions should be immediately corrected. Periodic inspections are recommended.
- Unless otherwise specified, the customer must provide and install explosion-proof conduit and fittings approved by the Canadian Standards Association (CSA) or listed by Underwriters Laboratories (UL). The customer is also responsible for having the system inspected and approved by the appropriate electrical inspector in accordance with local legal requirements and National Electrical Code Standards.
- EXT-401 telephone sets and associated external bells and control relays are designed to provide security against ignition of the surrounding atmosphere. All parts of the apparatus which might produce an electrical spark are completely enclosed. All passages to the outside are made such that any spark or flame will be cooled to a temperature below the ignition threshold before reaching the outside atmosphere.
- If the handset or cord is damaged, it must be replaced with part 301SC or 301SCPB handset assembly. Handsets and cords are not covered under warranty other than to be free of defects at time of installation.
- If the telephone is found to be defective or in need of repair, it must be returned to the manufacturer. No field repair is possible other than replacement of the handset and fuse.
- Telephones in good condition may be moved from one location to another.

## EXT 401 Models

PART NO.	DESCRIPTION
<b>No Volume Control – Has LINK &amp; REDIAL Buttons</b>	
P4011	No enhancements
P1011	Backplate & CE20 Line Powered Ringer
P4021	Ring Detect Relay
P1021	Ring Detect Relay, Backplate & CE20 Line Powered Ringer
P4022	Ring Detect Relay & Headset
P4023	Headset
P4036	Ring Detect Relay, Headset, Backplate & CE20 Line Powered Ringer
P4038	Headset, Backplate & CE20 Line Powered Ringer
<b>Volume Control Buttons Replace LINK &amp; REDIAL</b>	
P4012	No enhancements
P4030	Backplate & CE20 Line Powered Ringer
P4031	Ring Detect Relay
P4032	Ring Detect Relay, Backplate & CE20 Line Powered Ringer
P4033	Headset
P4034	Headset, Backplate & CE20 Line Powered Ringer
P4035	Ring Detect Relay & Headset
P4037	Ring Detect Relay, Headset, Backplate & CE20 Line Powered Ringer

## Options

20C - Twenty foot handset cord.

22AC - 22" armored cord.

HS - Headset with thirty foot cord.

## Installing the EXT-401

- **Declassify the hazardous location before proceeding with any installation or electrical wiring.**
- Follow all appropriate electrical codes and use only approved electrical fittings for the installation.
- Choose a wall location that is free of obstructions and permits space for ½" NPT conduit runs
- Ensure mounting can support 16.5lbs. (7.5kg), plus the weight of any peripheral equipment.
- Ensure that none of the electrical connection circuits are live.
- Use the template provided to locate and drill holes for mounting screws. Use ¼" bolts or screws to mount the unit.
- Secure the unit to the wall:
- Attach lower conduit nipples to the telephone and ensure a minimum five thread engagement.
- Mount an approved explosion proof junction box within 45.7 cm (18") of the telephone's lower sealing cavity and bring telephone wires into this box. Fittings compatible with 1/2 inch NPT nipples, conduit, or 1/2 inch explosion-proof flexible couplings not exceeding 45.7 mm (18 inches) may be fitted directly.

**Caution:** Installation or electrical wiring in a hazardous location could result in serious injury to personnel or damage to property.

**See:** Figure 3 - Typical Installation.

**See:** Figure 2 - Dimensions.

**Tip:** Use ¼" bolts or screws to secure the unit to the wall.

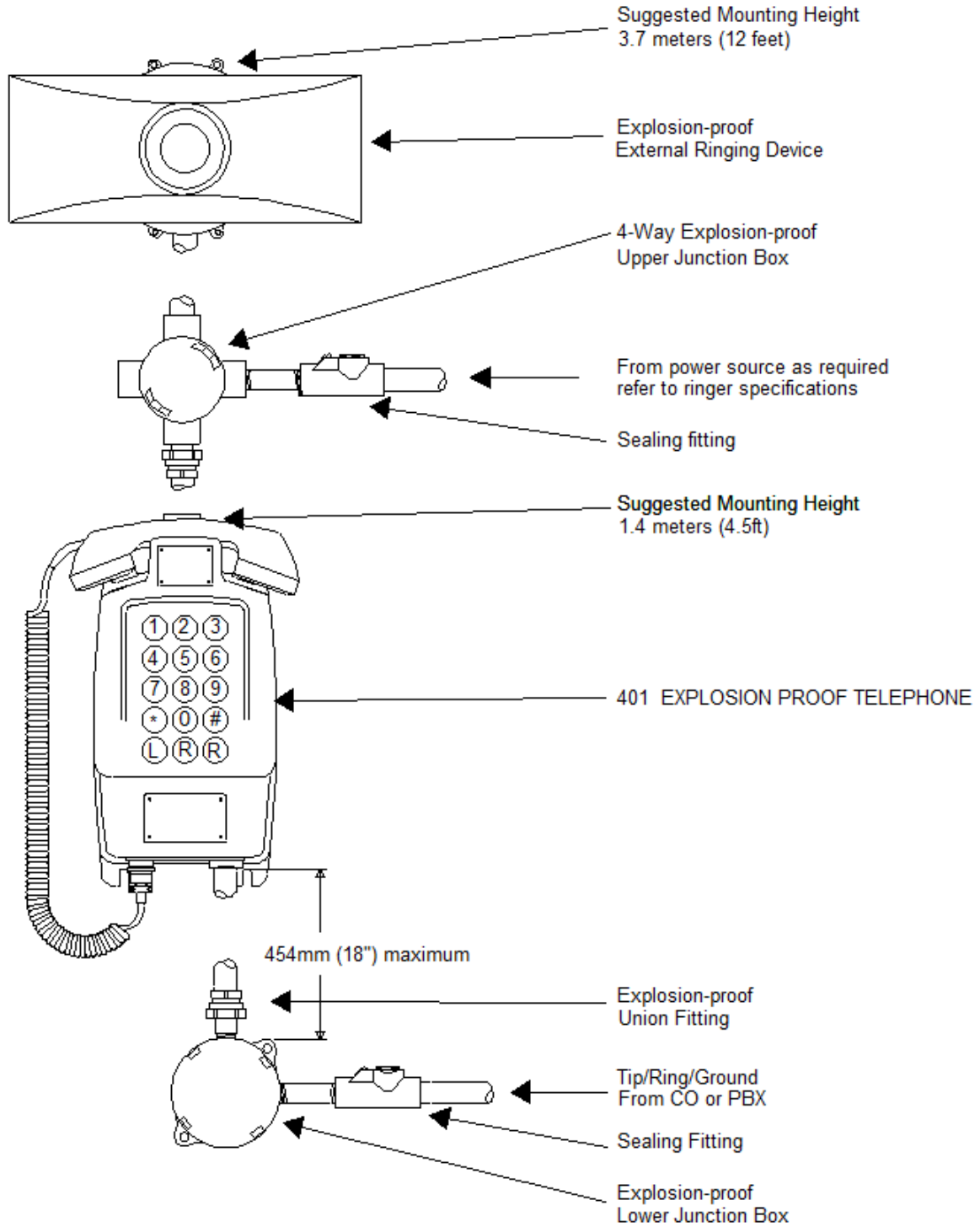

**Figure 3 - Typical Installation**

**Note: Models without volume control are not approved by the FCC and Industry Canada; they must therefore not be connected directly to a Central Office line.**

### Wiring For Tip & Ring

- After mounting the telephone follow these steps.  
**NOTE:** The ExT-401 is factory set for tone (DTMF) dialing unless pulse dialing was specified. Switching in the field is not possible.
- Run tip, ring and ground wires from the local exchange into the lower junction box. The tip and ring wires must **not** be connected to the local exchange until installation is completed. A sealing fitting must be installed within 45.7 cm (18") on the exchange side of the lower junction box.
- Attach the tip and ring wires to the orange and blue wires from telephone using twist on wire connectors. Attach #10 ring lugs to the end of the three green wires and attach these wires to the ground screw in the junction box.
- Check the wiring and close the junction box.

See: Figure 4 - Lower Junction Box Wiring

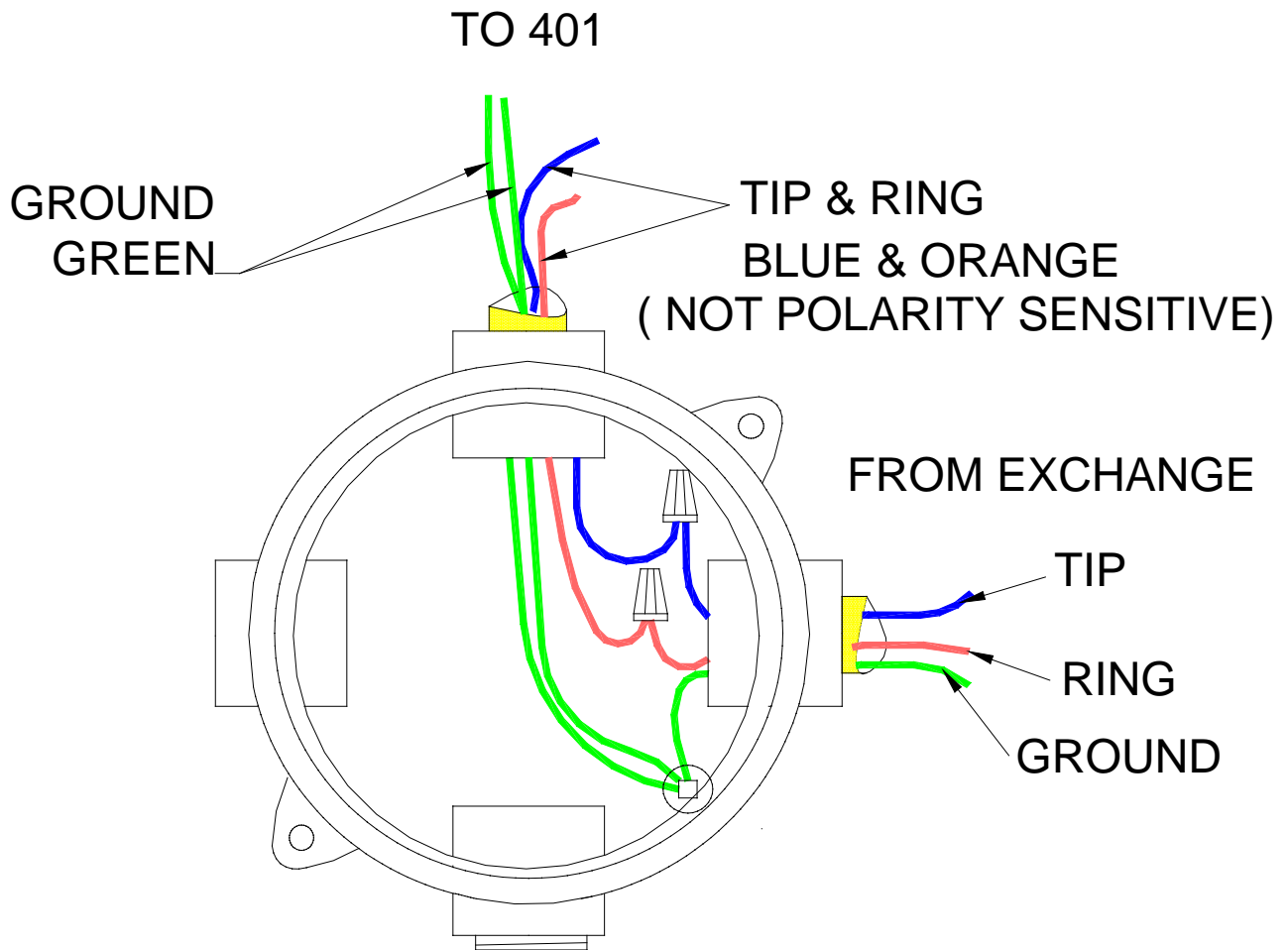

Figure 4 - Lower Junction Box Wiring



**Wiring For Peripheral Signaling Device**

- Mount the upper junction box within 45.7 cm (18") from the top of the telephone. Install conduit and signaling device wires to the upper junction box of the telephone.
- In the upper junction box, connect the incoming power hot lead to one of the white wires from the EXT-401 internal ring detect relay. Connect the other wire from the EXT-401 relay to one of the wires from the auxiliary signal device. Connect the other wire from the auxiliary signal device to the neutral power lead. Attach wires by the use of twist-on wire connectors.
- Secure the ground wire to the junction box ground screw.
- Check wiring and close the junction box.

See: Figure 3 - Typical Installation

See: Figure 5 - Upper Junction Box Wiring

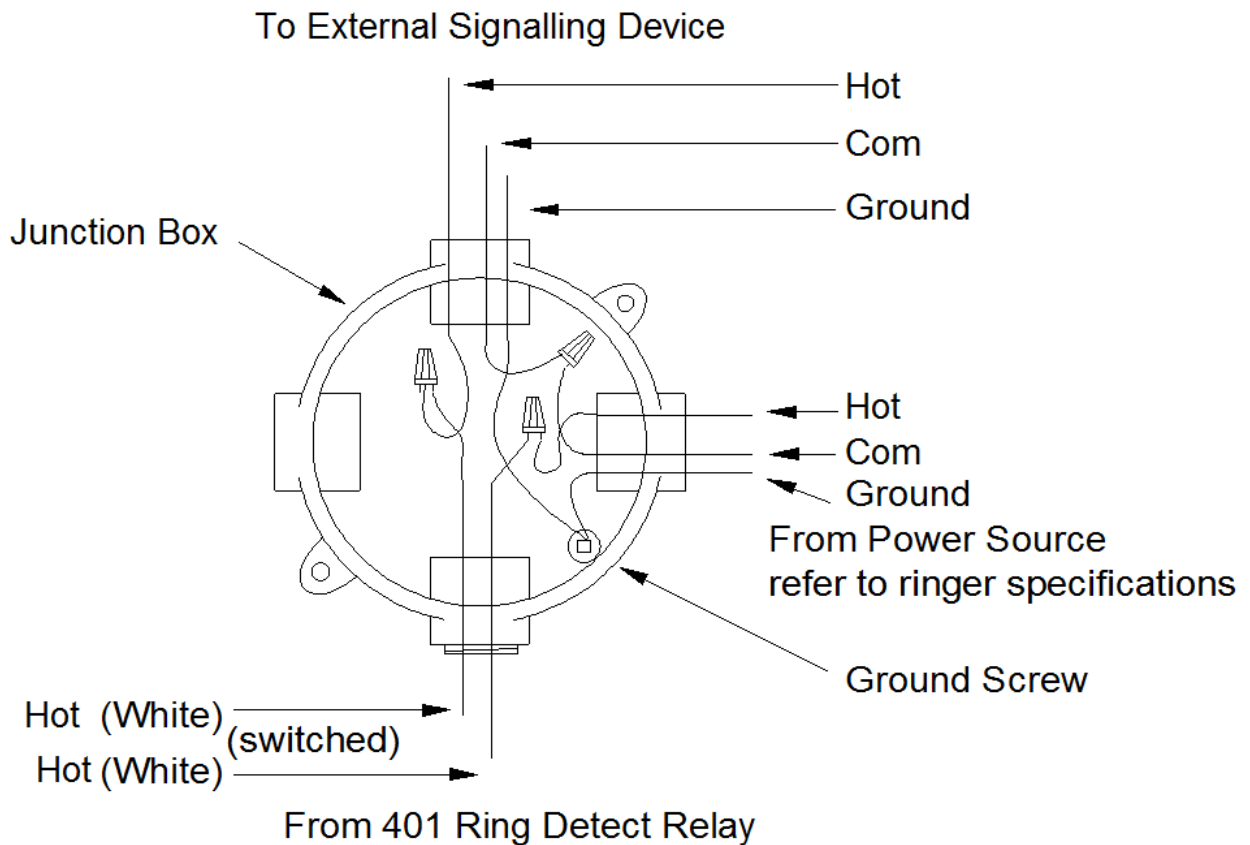

**Figure 5 - Upper Junction Box Wiring**

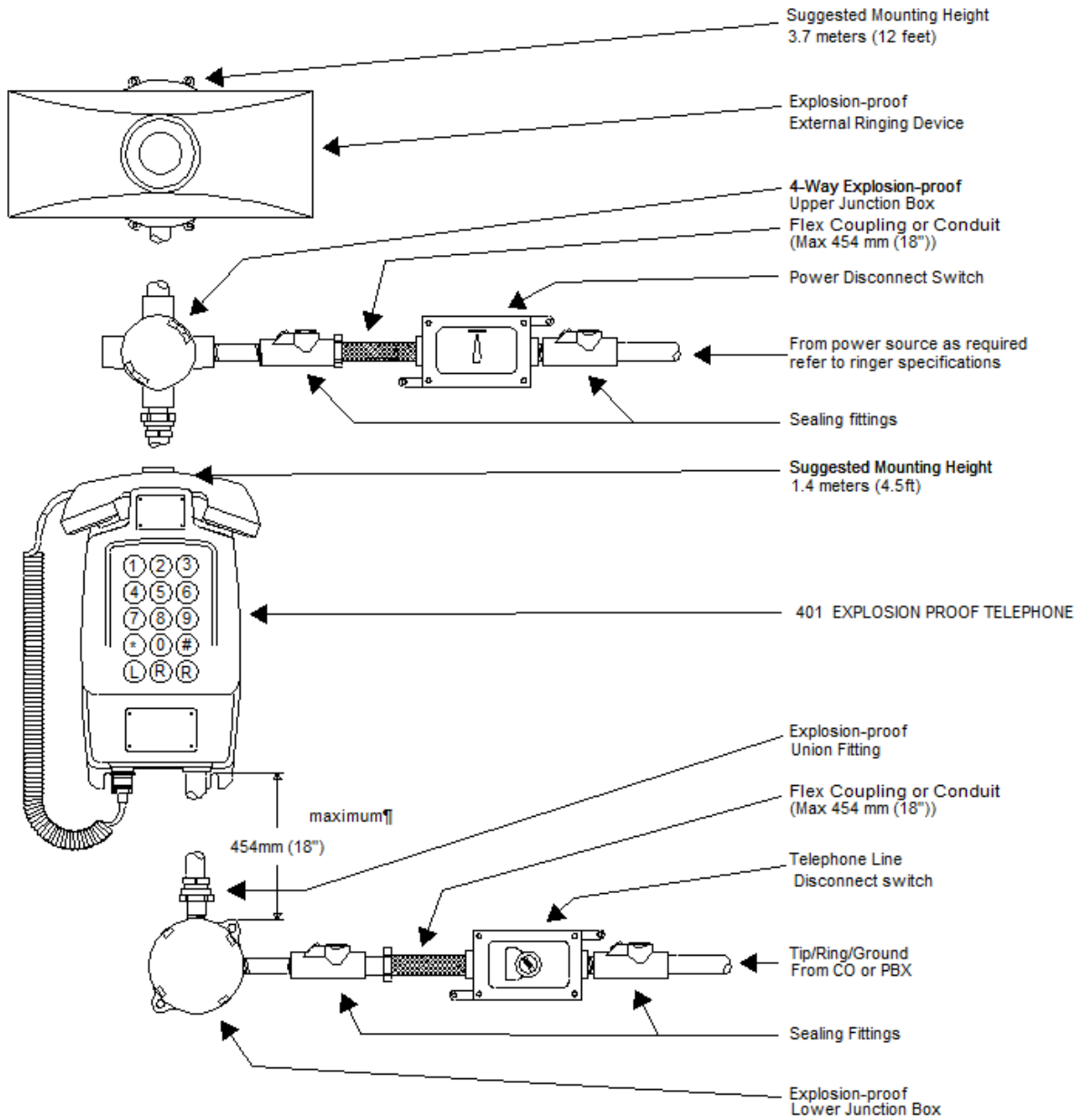

**Figure 6 - Typical Installation With Disconnect Switches**

### Wiring of Tip & Ring with Optional Disconnect Switch

**NOTE:** The ExT-401 is factory set for tone (DTMF) dialing unless pulse dialing was specified. Switching in the field is not possible.

- Mount an approved explosion proof disconnect switch within 45.7 cm (18") of the lower junction box and install a flexible coupling or conduit with a sealing fitting between the two.
- Ensure the disconnect switch is in the OFF position until the installation is complete and ready for use.
- Pull the tip, ring, and ground wires (18ga) from the disconnect switch to the lower junction box of telephone. Fill the sealing fitting with sealing compound as described in the instructions supplied by the manufacturer.
- Attach the tip and ring wires to the orange and blue wires from the telephone using twist on wire connectors. Attach #10 ring lugs to the end of the three green wires and attach these wires to the junction box ground screw.
- Inside the disconnect switch box attach the tip, ring and ground wires according to wiring diagram for the disconnect switch. Do not connect the tip and ring wires at the local exchange until installation is complete.
- Check wiring of junction box and power disconnect switch box before closing.

*See: Figure 7 - Optional Telephone Line Disconnect Switch Wiring*

*See: Figure 4 - Lower Junction Box Wiring*

*See: Figure 7 - Optional Telephone Line Disconnect Switch Wiring*

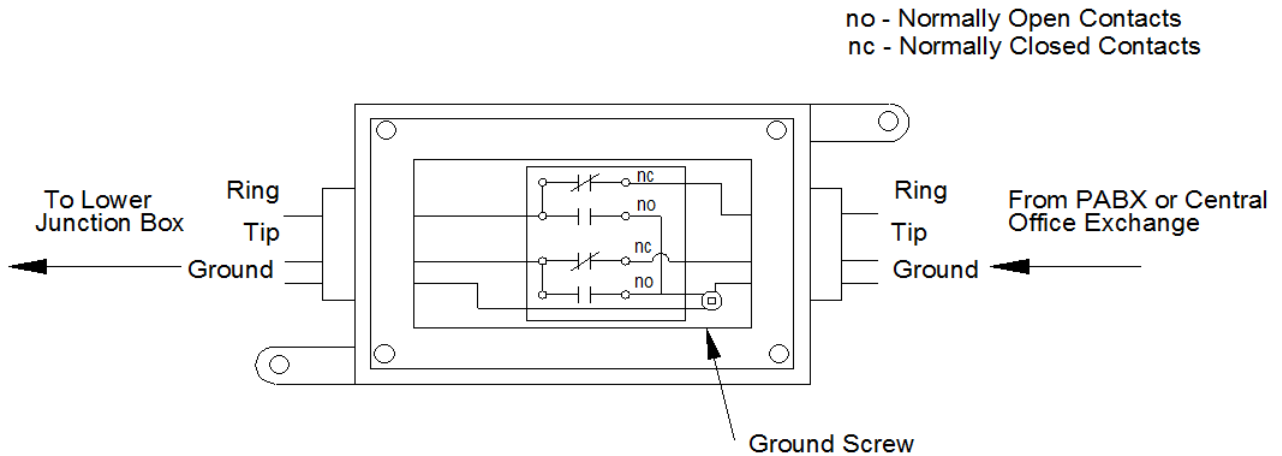

**Figure 7 - Optional Telephone Line Disconnect Switch Wiring**

### Installation of Peripheral Signaling Device with Power Disconnect Switch

- Mount the auxiliary signaling device in the desired location above the telephone. Run conduit and signaling device wires to the upper junction box.
- Mount an approved power disconnect switch within 45.7 cm (18") of the upper junction box and install a flexible coupling or conduit with a sealing fitting between the two. Pull three wires (18ga) from disconnect switch to upper junction box. Fill the fitting with sealing compound as shown in the manufacturer's instructions.
- In the upper junction box, connect the incoming power hot lead to one of the wires from the EXT-401 internal ring detect relay. Connect the other wire from the EXT-401 relay to one of the wires from the auxiliary signaling device. Connect the other wire from the auxiliary signaling device to the neutral power lead. Attach wires using a twist-on wire connector.
- Secure the ground wire from the power disconnect switch to the junction box ground screw.
- Ensure the disconnect switch is in the OFF position until installation is complete and the unit is ready for use. In the power disconnect switch box, attach the hot wire, neutral wire, and ground wires according to wiring diagram for the power disconnect switch box.
- Check the power disconnect switch and upper junction box before closing.

*See: Figure 8 - Power Disconnect Switch Wiring*

*See: Figure 5 - Upper Junction Box Wiring*

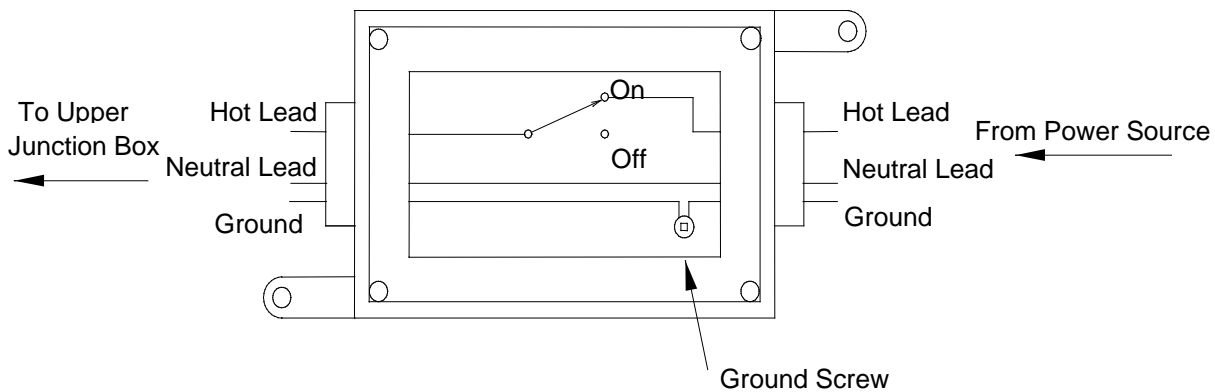

**Figure 8 - Power Disconnect Switch Wiring**

### Fuse Replacement

- Disconnect the telephone from tip and ring power supplied by the PABX or central office before attempting to replace the fuse.
- Remove the 1/2" NPT close up plug (item A) with a 1/4" Allen key.
- Remove fuse holder cap (item B) with a flat blade screwdriver. Rotate fuse holder cap 1/4 turn counterclockwise (to the left) to remove.
- Remove fuse (item C) from the cap and insert replacement fuse.

**See:** Figure 7 - Optional Telephone Line Disconnect Switch Wiring

**See:** Figure 9 - Fuse Replacement

### WARNING!

- Replace only with a 0.25 amp 2AG fast blow fuse. Failure to do so will void safety approval and warranties and may create an explosion hazard.
- With fuse mounted in the cap, re-install in the fuse holder with a flat blade screwdriver and rotate 1/4 turn clockwise (to the right) to lock in position.
- Screw the 1/2" NPT close-up plug into housing with a minimum of five full threads of engagement.

**See:** Product Specifications

### ATTENTION!

- CSA & UL standards require five full threads of engagement for the close-up plug.

### NOTES

- A field replaceable fuse is available on EXT-401 models manufactured after Jan. 1, 1997.
- If, on reconnecting power, the fuse fails, check the telephone system wiring. The fuse protects the tip and ring line from the telephone system. It is usually powered at 48 volts DC and should not be connected to 120 volts AC.

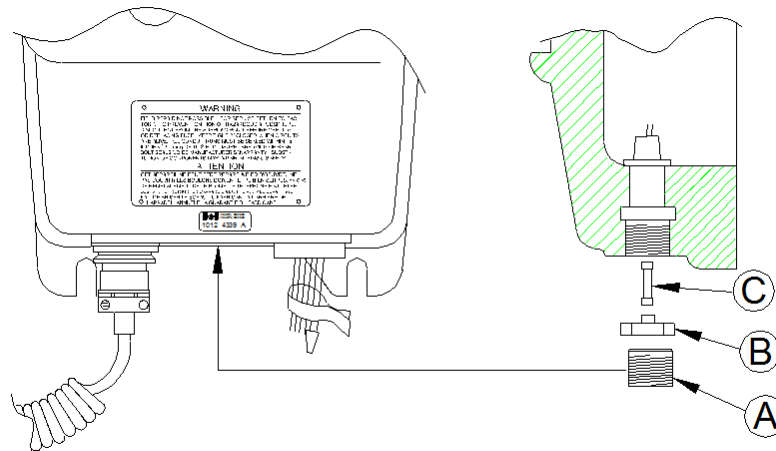

**Figure 9 - Fuse Replacement**

### Replacement of Telephone Handset Assembly

**Note:** The standard handset assembly for the EXT-401 telephone has a 3.0 m (10 ft) coiled cord. A 6.0m (20 ft) long coiled cord and a 22" armored cord are available as options. These assemblies are designed specifically for use with the EXT-401 telephone. If damaged the assembly may be replaced in the field. Only a 301SC, 301SCP (push to talk) or 22AC-401 armored cord handset assembly may be used with the EXT-401 telephone. Alternatively an ISH1125 headset assembly may be used in place of a handset.

- Completely unscrew the upper knurled collar.
- Pull the old plug straight down.
- Inspect the inside of the socket and the threads for dirt or damage; clean as necessary.
- For safe installation, the new handset **MUST** be placed firmly in the cradle **PRIOR** to engaging the plug in socket.
- Bring the new plug up to the socket and rotate the plug until the slot in the shell lines up with the key in the socket. Insert plug into socket.
- Screw the upper knurled collar onto the socket. Hand tighten only, **Do Not use a wrench.**
- Call back and forth to another set to check functionality.
- Hang up firmly between each call.
- **NOTE:** If the handset is being replaced because of an apparent telephone malfunction, and the replacement fails to restore normal operations, contact the manufacturer to arrange return of the unit for repair.

*See: Figure 10 -  
Handset Replacement*

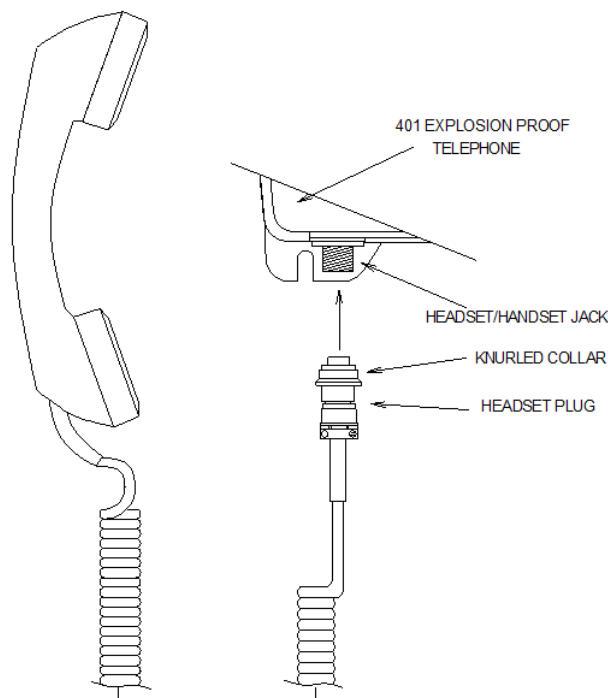
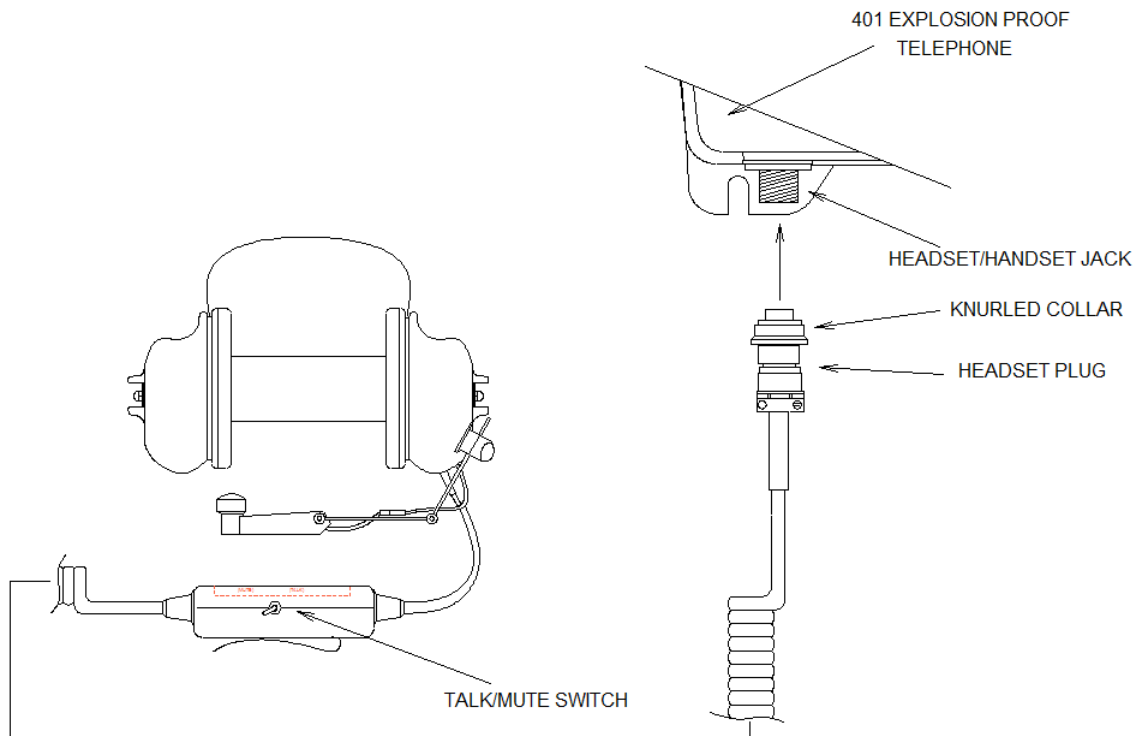

**Figure 10 - Handset Replacement**

### Replacement of ISH1125 Headset

- **Note:** The headset cord is a 9.1 m (30 ft) long coiled cable designed specifically for use with the EXT-401 telephone. If damaged, the assembly may be replaced in the field. Only an ISH1125 headset assembly or a 301SC or 301SCPB (push to talk) handset assembly may be connected to the EXT-401 explosion proof telephone.
- Completely unscrew the upper knurled collar.
- Pull the old plug straight down.
- Inspect the inside of the socket and the threads for dirt or damage; clean as necessary.
- For safe installation, the new headset **MUST** be placed on the headset arm **PRIOR** to engaging the plug in socket.
- Bring the new plug up to the socket and rotate the plug until the slot in the shell lines up with the key in the socket. Insert plug into socket.
- Screw the upper knurled collar onto the socket. Hand tighten only, **Do not use a wrench.**
- Call back and forth to another set to check functionality.
- Hang the headset onto the hook switch arm between each call.
- **NOTE:** If the headset is being replaced because of an apparent telephone malfunction, and the replacement fails to restore normal operations, contact the manufacturer to arrange return of the unit for repair.

See: Figure 11 -  
Headset Replacement



**Figure 11 - Headset Replacement**

### Operating Instructions

#### EXT-401 TELEPHONE WITH HANDSET OR HEADSET

##### Handset

- Remove handset from cradle.
- Listen for a dial tone and then dial the appropriate digits for the feature desired.
- Upon completing a call hang up by returning the handset to the cradle.
- Calls are answered by lifting the handset from the cradle.
- To make another call without returning the handset to the cradle, press the RLS (release) button.

##### Headset

- Remove the headset and place it over the head; raise the hook switch arm to the off hook (vertical) position.
- Listen for a dial tone and then dial the appropriate digits for the feature desired.
- Ensure that the belt hook TALK/MUTE switch is in the TALK position. This switch does not affect voice reception or control on-hook/off-hook operation of the telephone.
- Upon completing a call, return hook switch arm to the on-hook (horizontal) position).
- Calls are answered by lifting the hook switch arm.
- To make another call without returning the headset to the hook switch arm press the RLS (release) button.

**See:**

*Figure 1 - Features*

**See:** *Figure 12 - Headset Hook Switch Operation*

**See:** *Figure 11 - Headset Replacement*

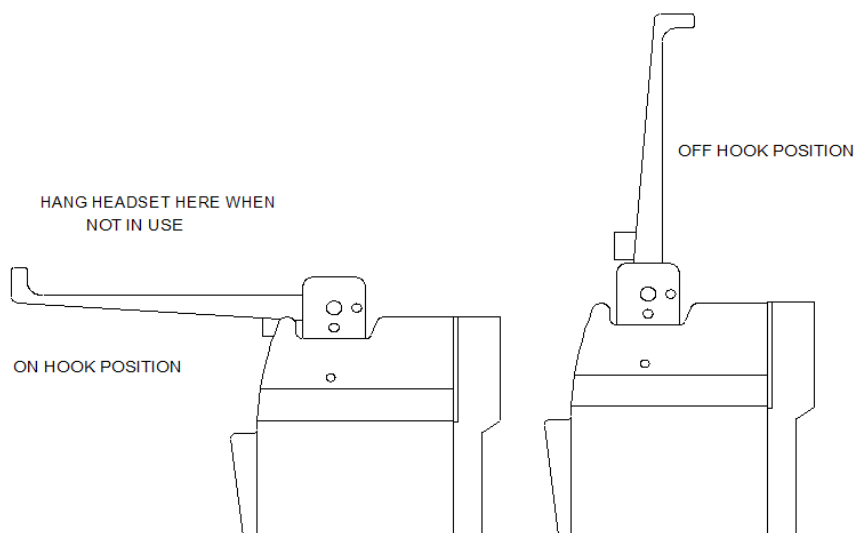

**Figure 12 - Headset Hook Switch Operation**



**Product Specifications**

<b><i>Electrical Performance</i></b>	
AUDIBLE RANGE FREQUENCY RESPONSE	300 – 3400 Hz
DIALING METHOD	DTMF OR 40/60 PULSE, 10 PPS
TRANSMIT OBJECTIVE LOUDNESS RATING (TOLR)	-38 +/- 4 dB
RECEIVE OBJECTIVE LOUDNESS RATING (ROLR)	TYPICAL 52 +/- 4 dB
SIDE TONE OBJECTIVE LOUDNESS RATING (SOLR)	TYPICAL 20 +/- 3 dB
RINGER OUTPUT	N/A
FCC RINGER EQUIVALENCE WITH OPTIONAL RING DETECT RELAY INSTALLED	0.9 A, 1.9B
RING DETECT RELAY RATINGS (OPTIONAL)	10 AMPS AT 250VAC
FLASH	600 MSEC TIMED DISCONNECT
REDIAL	13 DIGITS MAXIMUM
MAXIMUM LOOP	15 KFT OF 22 AWG COPPER
<b><i>Electrical Requirements</i></b>	
LINE VOLTAGE	24 – 56 VDC
LOOP CURRENT	20 - 120 MA
RINGER DETECT RELAY SENSITIVITY (OPTIONAL)	40 – 100 V, 16 – 25 Hz
CONNECTION METHOD	FACTORY SEALED WIRING THROUGH ½" CONDUIT ENTRY
FUSE	2AG 0.25 AMP 250 VOLT
<b><i>Environmental</i></b>	
WEATHERPROOF & WATERTIGHT	ENCLOSURE NEMA 4
TEMPERATURE	-40° TO +60° C (-40° TO 140°F)
HUMIDITY	0 TO 95% RH NON CONDENSING
DUSTPROOF	¾" FLAT FLANGE DUSTPROOF JOINTS
<b><i>Mechanical</i></b>	
HOOK SWITCH (CRADLE SWITCH) LIFE	>1 000 000 OPERATIONS
BODY CONSTRUCTION	COPPER FREE CAST ALUMINUM WITH POWDER COAT FINISH
DIMENSIONS	325 x 173 x 122 MM (12.8 x 6.8 x 4.8 INCHES)
NET WEIGHT	7.95 KG (17.5 LBS.)
HANDSET MATERIAL	HIGH IMPACT ABS
HANDSET CORD	3.0 M (10 FT) FIELD REPLACEABLE WITH LOW TEMPERATURE POLYURETHANE JACKET
HANDSET CORD (OPTIONAL)	6.0 M (20 FT) FIELD REPLACEABLE WITH LOW TEMPERATURE POLYURETHANE JACKET
MICROPHONE	DYNAMIC

RECEIVER	HEARING AID COMPATIBLE
DIAL PAD	OVERSIZED ALUMINUM BUTTONS ON 1.125" GRID
STANDARD MOUNTING	VERTICAL WALL
CONNECTION FITTINGS	½" NPT CONDUIT ENTRY
<b>Compliances</b>	
INDUSTRY CANADA *	1012 4339 A
FCC *	HQHCAN-65560-TE-E
CSA	LR65547-18
UL	13X8, & E117495
WEATHERPROOF & WATERTIGHT	ENCLOSURE NEMA 4
HAZARDOUS LOCATION APPROVALS	CLASS I, DIVISION 1. GROUPS B, C & D CLASS II, DIVISION 1, GROUPS E, F & G
ENVIRONMENTAL SURVIVABILITY	MIL-STD-810E

\* ONLY MODELS WITH VOLUME CONTROL – SEE EXT 401 MODELS



Figure 13 - I.D. and Compliance

**Replacement Parts**

Part No.	Description
P007111	Standard Handset Assembly C/W 10 foot Curly Cord
P007121	Standard Handset Assembly C/W 20 foot Curly Cord
P005574	Standard Handset Assembly C/W 22" Armored Cord
P007130	Push-to-Talk Handset Assembly C/W 10 foot Curly Cord
P007131	Push-to-Talk Handset Assembly C/W 20 foot Curly Cord
P007221	Headset Assembly C/W 30 foot Curly Cord
P004022	Fuse – 2AG 0.25 Amp 250 Volt Fast Blow

## Government Certification

Attached to the telephone are labels for *Industry Canada* and the *United States Federal Communications Commission*. These identify equipment certifications indicating the 60 and 70 series telephones meet certain telecommunications network protective, operational and safety requirements. These agencies do not guarantee the equipment will operate to the user's satisfaction.

Before installing this telephone equipment, users should ensure it is permissible to connect the equipment to facilities of the local telecommunications company.

Equipment must be installed using acceptable connection methods. In some cases, the telephone users inside wiring, associated with a single line service, may be extended by a certified connector assembly (telephone extension cord). The customer should be aware that in some situations compliance with the above conditions may not prevent degradation of service.

Repairs to certified equipment should be made by a supplier designated authorized maintenance facility.

For their own protection users should ensure the electrical ground connections of the power utility, telephone lines and internal metallic water pipe systems, if present, are connected. This precaution may be particularly important in rural areas.

**CAUTION:** Users should not attempt to make ground connections, but should contact the appropriate electrical inspection authority or electrician.

### **Load Number (LN)**

The Load Number (LN) assigned to each terminal device denotes the percentage of the total load to be connected to a telephone loop used by the device. Termination on a loop may consist of any combination of devices subject only to the requirement that the total of the Load Numbers of all the devices does not exceed 100.

### **Notification to Telephone Company**

Upon request, the customer must notify the telephone company of the particular line to which the connection will be made and provide the Industry Canada or FCC registration number. The local telephone company may request disconnection of the telephone where alterations or malfunctions affect the telephone's performance.

### **United States Federal Communications Commission**

This equipment generates, uses and can radiate radio frequency energy, and if not installed and used in accordance with the instruction manual, may cause interference to radio communications. It has been tested and found to comply with the limits for Class A computing device pursuant to Subpart J of Part 15 of FCC rules, which are designed to provide reasonable protection against such interference when operated in a commercial environment. Operation of this equipment in a residential area is likely to cause interference in which case the user, at his own expense, will be required to take whatever measures may be required to correct the interference.

### **Interference**

There is no guarantee that interference will not occur in a particular installation. If interference to radio or television reception from this equipment is suspected, proceed as follows:

1. Unplug the set, check for the interference.
2. Re-orient the receiving antenna.
3. Relocate the set with respect to the receiver.
4. Move the set away from the receiver.

If necessary, consult the supplier or an experienced radio/television technician for additional suggestions.

### **FCC Rules and Ringer Equivalence Number**

This equipment complies with Part 68 of the FCC Rules. On the side of this equipment is a label that contains, among other information, the FCC registration number and ringer equivalence number (REN) for this equipment. If requested, this information must be provided to the telephone company.

The REN is used to determine the quantity of devices which may be connected to the telephone line. Excessive RENs on the telephone line may result in the devices not ringing in response to an incoming call. In most, but not all areas, the sum of the RENs should not exceed five. To be certain of the number of devices that may be connected to the line, as determined by the total RENs, contact the telephone company to determine the maximum REN for the calling area.

### **Service changes and Limitations**

The telephone company may make changes in its facilities, equipment, operations, or procedures that could affect the operation of the equipment. If this happens, the telephone company will provide advance notice in order for you to make the necessary modifications in order to maintain uninterrupted service.

This equipment cannot be used on public coin telephone service as provided by your telephone company. Connection to party line service is subject to state tariffs (contact the state public utility commission, public service commission or corporate commission for information.)

### **Warranty**

Guardian Telecom warrants your product to be free of defects in material and workmanship for a period of one year. Guardian Telecom will repair or replace any defective unit that is under warranty free of charge.

This warranty is null and void if any non-authorized modifications have been made to this product, or if it has been subjected to misuse, neglect, or accident. This warranty covers bench repairs only; such repairs must be made at Guardian Telecom or an authorized service depot. Guardian Telecom is not responsible for costs incurred for on-site service calls, freight, or brokerage.

***A return authorization must be obtained prior to warranty claims or repairs.***

### **Disclaimer**

The products covered by this manual are designed for use in Industrial Environments and/or Hazardous Locations. Due to the range of possible applications for these instruments the manufacturer will not be responsible for damages or losses of any kind suffered as a result of the use of this product, including consequential damages.

### **Warning**

Guardian's Model EXT-401 Explosion Proof telephone must **NOT** be opened by the user, doing so **voids** the warranty and safety approvals. The EXT-401 handset and fuse are externally accessible parts which may be safely serviced by the user following procedures described in the manual.

### **Service Telephone Number**

#### ***1-800-363-8010***

Guardian Telecom provides a customer service telephone number which is toll-free within North America. If you need assistance when installing or operating this product, please call the toll-free telephone number between regular business hours (8:00AM-5:00PM), Mountain Standard Time. If you are calling outside of regular business hours, please leave a detailed message, and a member of Guardian Telecom's Service Department will return your call as soon as possible. If your product requires service, Guardian personnel will supply you with an RMA (return materials authorization) number over the telephone or through our web site product return page. This number must be included with your return address and the name of the person to contact.

**Guardian Telecom Inc.**  
**Toll-free 1-800-363-8010**  
**Ph. (403) 258-3100**  
**Fax. (403) 253-4967**  
**[www.guardiantelecom.com](http://www.guardiantelecom.com)**

### **Feedback**

Guardian Telecom continually strives to make reliable, durable, and easy to use products. If you, as an installer or user of our equipment, have any suggestions for improvements to this or any of our products or documents, including this manual, we would appreciate hearing from you.

### Guardian Product Return

<p>Guardian products have been quality tested and are in full working order when shipped from the factory, given the rugged nature of these products shipping is not expected to damage a unit. In the unlikely event of a malfunction, Guardian follows the three step procedure below.</p>
<p><b><i>Step I - On-Site Correction</i></b></p>
<ul style="list-style-type: none"> <li>• The most common source of difficulties with a new product is improper installation in one of two ways: incorrect wiring connections or connection to an incorrect power source.</li> </ul>
<ul style="list-style-type: none"> <li>• Product wiring needs to be properly connected to the on-site wiring. Correct wiring instructions are shown in the user manual included with the product.</li> </ul>
<ul style="list-style-type: none"> <li>• Connecting a telephone to a standard power source, rather than tip &amp; ring, will blow the telephone's internal, user-replaceable fuse. In the event of fuse burn-out, disconnect the telephone from the power source, replace the fuse, and reconnect following the wiring diagrams provided with the product.</li> </ul>
<p><b><i>Step II - Return Materials Authorization (RMA)</i></b></p>
<ul style="list-style-type: none"> <li>• When a product has been installed following user manual instructions, and the unit fails to operate, the user must contact Guardian Telecom to obtain authorization to return the product. This can be done by completing a RMA form online at <a href="http://www.guardiantelecom.com">www.guardiantelecom.com</a>, or by calling the service telephone number given in this manual.</li> </ul>
<ul style="list-style-type: none"> <li>• After providing information on the product, the owner and the nature of the problem, Guardian will issue a RMA number, to be shown on documentation returned with the product.</li> </ul>
<ul style="list-style-type: none"> <li>• In addition to the RMA number, shipping documents should include name, address and telephone number of the owner along with contact information for the person responsible for the repair and/or the user who identified the malfunction.</li> </ul>
<ul style="list-style-type: none"> <li>• (Where a product is being returned for repair from outside of Canada, customs documentation must show the product's serial number, date of export [date of purchase], and a notation that the equipment is: "Canadian goods returning.")</li> </ul>
<p><b><i>Step III - Factory Authorized Service</i></b></p>
<ul style="list-style-type: none"> <li>• Once received, each product is carefully inspected and tested. If the product is under warranty, repairs are completed and the product returned to the owner, generally within five working days of receipt by the factory.</li> </ul>
<ul style="list-style-type: none"> <li>• A product that has been subjected to misuse, neglect or accident or is beyond the warranty period will be evaluated. The service department will provide the owner's representative with a repair cost estimate. Once approved, repairs are completed and the product returned, generally within five working days.</li> </ul>

**APPENDIX A - Hazardous Location Classification**

## CLASS I, DIVISION 1 &amp; 2, GROUP B

acrolein	formaldehyde(gas)	propyl nitrate
butadiene	hydrogen	ethylene oxide
manufactured gases containing more than 30% hydrogen(by volume)		propylene oxide

## CLASS I, DIVISION 1 &amp; 2, GROUP C

acetaldehyde	epichlorohydrin	methyl formal
allyl alcohol	ethylene	methyl mercaptan
butyl mercaptan	ethylenimine	monomethyl hydrazine
n-butylaldehyde	ethyl mercaptan	morpholine
carbon monoxide	n-ethyl morpholine	nitroethane
crotonaldehyde	hydrogen cyanide	nitromethane
dicyclopentadiene	hydrogen selenide	2-nitropropane
diethyl ether	hydrogen sulfide	propionaldehyde
diethylamine	isobutyraldehyde	n-propyl ether
di-isopropylamine	Isopropyl glycidyl ether	tetrahydrofuran
dimethylamine	methylacetylene	triethylamine
1,4-dioxane	methylacetylene-propadiene	unsymmetrical dimethyl hydrazine
di-n-propylamine	methyl ether	valeraldehyde

## CLASS I, DIVISION 1 &amp; 2, GROUP D

acetic acid	ethyl benzene	methyl isocyanate
acetone	ethyl chloride	methyl methacrylate
acetonitrile	ethylenediamine	2-methyl-1-propanol
acrylonitrile	ethylene dichloride	2-methyl-2-propanol
allyl chloride	ethyl glycol monomethyl ether	naptha
ammonia (3)	ethyl formate	nonane
n-amyl acetate	gasoline	nonene
sec-amyl acetate	heptane	octane
benzene	heptene	octene
butane	hexane	pentane
1-butanol (butyl alcohol)	2-hexanone	1-pentanol
2-butanol (secondary butyl alcohol)	hexenes	2-pentanone
n-butyl acetate	isoamyl acetate	1-pentene
sec-butyl acetate	isoamyl alcohol	petroleum naptha
butylamine	isobutyl acrylate	propane
butylene	isoprene	1-propanol
chlorobenzene	isopropyl acetate	2-propanol
chloroprene	isopropylamine	n-propyl acetate
cyclohexane	isopropyl ether	propylene
cyclohexene	liquefied petroleum gas	propylene dichloride
cyclopropane	mesityl oxide	propylene oxide
1,1-dichloroethane	methane	pyridine
1,2-dichloroethylene	methanol	styrene
1,3-dichloropropene	methyl acetate	toluene
di-isobutylene	methyl acrylate	tripropylamine
ethane	methylamine	turpentine
ethanol	methylcyclohexane	vinyl acetate
ethyl acetate	methyl ethyl ketone	vinyl chloride
ethyl acrylate	methyl formate	vinylidene chloride
ethylamine	methyl isobutyl ketone	xylene

**APPENDIX A (cont.)**

## CLASS II, DIVISION 1 &amp; 2, GROUP E

Atmospheres containing combustible metal dusts regardless of resistivity, or other combustible dusts of similarly hazardous characteristics having resistivity of less than  $10^5$  ohm-centimeter

## CLASS II, DIVISION 1 &amp; 2, GROUP F

Atmospheres containing carbon black, charcoal, coal or coke dusts which have more than eight percent total volatile material (carbon black per ASTM D1620; charcoal, coal and coke dusts per ASTM D271) or atmospheres containing these dusts sensitized by other materials so that they present an explosion hazard, and having resistivity greater than 100 ohm-centimeter but equal to or less than  $10^8$  ohm centimeter.

## CLASS II, DIVISION 1 &amp; 2, GROUP G

Atmospheres containing combustible dusts having resistivity of 100000 ohm-centimeter or greater.

**NOTE:** *This appendix is a summary of information contained in the National Electrical Code. Please refer to local applicable Electrical Codes for details and latest update.*

**APPENDIX B - Applications**

The EXT-401 Explosion Proof Telephone has been approved by Canadian Standards Association (CSA) and listed by Underwriters' Laboratories (UL) for use in explosive atmospheres.

Locations that may require explosion-proof equipment include:

- chemical plants
- petrochemical plants
- offshore drilling rigs
- land-based drilling rigs
- gas plants
- oil & gas metering facilities
- refineries
- fueling stations
- breweries and distilleries
- defense installations
- munitions storage depots
- missile silos
- liquefied natural gas terminals
- tankers and tanker depots
- paint and varnish manufacturing plants
- grain processing and similar industries
- bulk loading stations
- fertilizer plants



**Guardian Telecom Inc.**  
**Toll-free 1-800-363-8010**  
**Phone (403) 258-3100**  
**Fax. (403) 253-4967**  
**www.guardiantelecom.com**  
**E-mail: [sales@guardiantelecom.com](mailto:sales@guardiantelecom.com)**  
*(Click to open message box)*

***CONNECTED. PROTECTED.***

© Guardian Telecom Inc. 2015